



Position Measurement Sensors



www.opkon.com.tr

General Catalogue



OPKON Optic Electronic Ltd. established in 1993 in Istanbul / Turkey by Electronic Engineer Mustafa Kenan Ozeren. Company philosophy is developing, designing and manufacturing electronic sensors and devices, with European quality, and distribute all over the world.

OPKON Ltd. has all R&D and manufacturing facilities in Istanbul, which has 2500 sq meter production area, 60 technicians and engineers with many years experience. Company is certified with ISO 9001-2008 - ISO 10002-2004

OPKON Production Portfolio :

- Linear Potentiometer
 - Standard Series
 - Electronic Conditioner Circuit (0-10V,0-20mA,4-20mA) Series
 - Slim Body Series
 - Ultra Slim Body Series
- Draw Wire Potentiometer
- Contactless Magnetostrictive Position Sensor
- Optic Rotary Incremental Encoder
- Magnetic Rotary Incremental / Absolute Encoder
- Draw Wire Encoder
- Voltage Output, Absolute Encoder
- Magnetic Reader Head, Magnetic Tape
- Press Brake Scale
- Panel Type Measurement And Control Equipment

OPKON production portfolio covers very wide range of industry, such as;

- Plastic / Metal Injection Moulding
- Textile
- Marble / Stone
- Packaging
- Printing
- Wood Processing
- Press Brakes
- Roll Bending
- Metal Cutting / Forming
- Elevator
- Profile and Metal Processing
- Cranes / Lift
- Hydraulic Press
- Medical
- General Automation Applications

OPKON has sales network in 6 continents with 28 countries official distributors.

Company exports to Germany, Italy, Spain, Portugal, Netherland, Greece, Bulgaria and other European community countries, USA, Canada, Brazil, Mexico, Argentina, South Africa, Middle east countries, India, China, Korea, Taiwan, Australia and others.

Linear Potentiometers
Slim Body Series

Linear Potentiometers
Conditioner Circuit

Linear Potentiometers
BUS Output

Magnetostrictive Position
Sensors

Magnetostrictive
BUS Output Position Sensors

Magnetic Linear
Encoders

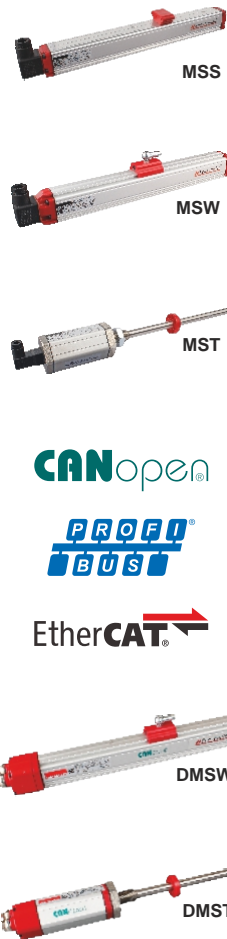
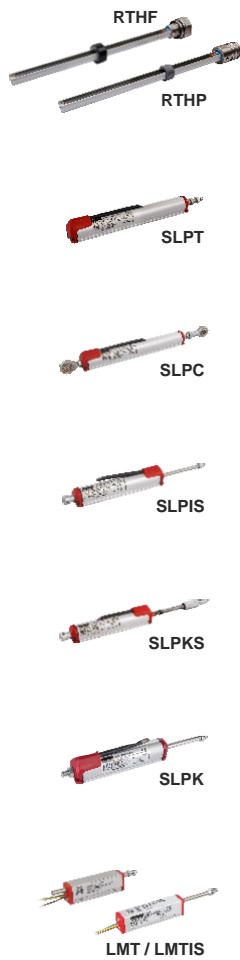



PRI 100H



PRI 80H



PRI 58AR



PRI 58BR



PRI 50 SH/H
PRI 58 SH/H



PRI 50R



PRI 40H



PRI 40R



MRI 58AR



MRI 58BR



MRI 50SH



MRI 50



MRI 40



ERC10



DWP



DWE

Draw Wire Potentiometers / Encoders

Draw Wire Potentiometers/Encoders

Optic Rotary Absolute Encoders

Optic Rotary Absolute Encoders

Magnetic Rotary Encoders

Magnetic Rotary Encoders

Optic Rotary Incremental Encoders

Optic Rotary Incremental Encoders



All technical data have been established under laboratory condition with great care. Data of our products do not confirm necessarily completely to chosen standards. They are for information only. Because of different application conditions, properties can not be assured. No responsibility for any damages are assumed and the end user has to ensure by his own that the product is suitable for his application. The rights to change data without advance notice is reserved.

Linear Potentiometer

- Measuring range 30 - 1000 mm
- Long mechanical life 100 million movements
- Excellent repeatability <0.01 mm
- Infinite resolution
- 5 kOhm : 30 ... 600 mm
- 10 kOhm : 650 ... 1000 mm



Technical specifications

Measurement stroke	30 to 1000 mm
Linearity	±%0,05 (>200 mm), ±%0,1 (130 - 200 mm), ±%0,2 (75 - 130 mm), ±%0,5 (<75 mm)
Repeatability	< 0.01 mm
Resolution	Infinite
Resistance	5 kOhm : 30 ... 600 mm 10 kOhm : 650 ... 1000 mm
Resistance tolerance	± %20
Load resistance	100 kOhm min.
Recommended cursor current	<1 µA
Permissible applied voltage	28 VDC max.
Electrical connections	4 pin connector
Displacement speed	< 5 m/s
Mechanical life	100 million movement
Case dimensions	33 mm x 33 mm
Case material	Anodized aluminium
Rod material	Stainless steel
Rod diameter	Ø6 mm
Mechanical fixing	Variable brackets
IP degree	IP 65
Operating temperature	-20°C ... +80°C
Storage temperature	-30°C ... +90°C

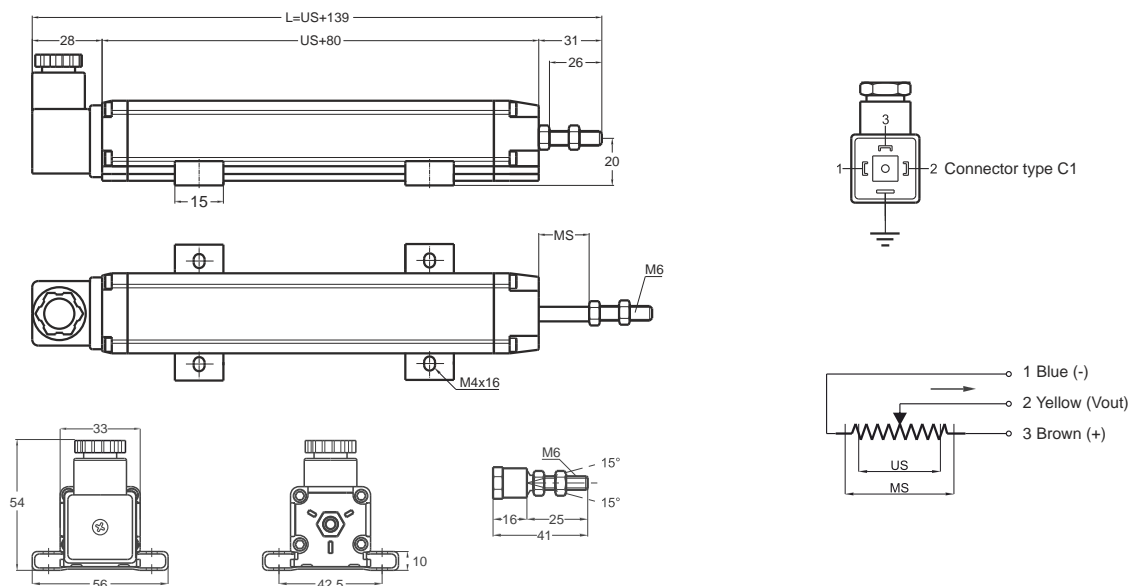

RTL (mm)	30	50	75	100	125	130	150	175	200	225	250	275	300	325	350	375	400	450	500	550	600	650	700	750	800	850	900	1000
US (Usefull Stroke)	30	50	75	100	125	130	150	175	200	225	250	275	300	325	350	375	400	450	500	550	600	650	700	750	800	850	900	1000
MS ±0.5 (Mechanical Stroke)	33	53	73	103	128	133	153	178	203	228	253	278	303	328	353	373	403	453	503	553	603	653	703	753	803	853	903	1003
L (Total Length)	169	189	214	239	264	269	289	314	339	364	389	414	439	464	489	514	539	589	639	689	739	789	839	889	939	989	1039	1139

Model	Measurement stroke (mm)	Linearity (%)	Resistance (KOhm)	Connector / Cable
(example) RTL	500	D	5K	C1
RTL	30 ... 1000 mm	D: ±%0,05 (>200 mm), ±%0,1 (130 - 200 mm), ±%0,2 (75 - 130 mm), ±%0,5 (<75 mm)	5K: 5 kOhm 10K: 10 kOhm	C1: 4 pin connector

Linear Potentiometers
Slim Body Series
Linear Potentiometers
Conditioner Circuit
Magnetostrictive Position
Sensors
Magnetic Linear
Incremental Encoders
Draw Wire
Potentiometers/Encoders
Optic Rotary Absolute
Encoders
Magnetic Rotary
Encoders
Optic Rotary Incremental
Encoders

Linear Potentiometer

Measuring range 100 - 1950 mm
 Long mechanical life 100 million movements
 Excellent repeatability <0.01 mm
 Infinite resolution
 5 kOhm : 100 ... 600 mm
 10 kOhm : 650 ... 1000 mm
 20 kOhm : 1250 ... 1950 mm



Technical specifications

Measurement stroke	100 to 1950 mm
Linearity	$\pm 0,05$ (>200 mm), $\pm 0,1$ (130 - 200 mm), $\pm 0,2$ (75 - 130 mm), $\pm 0,5$ (<75 mm)
Repeatability	< 0,01 mm
Resolution	Infinite
Resistance	5 kOhm : 100 ... 600 mm 10 kOhm : 650 ... 1000 mm 20 kOhm : 1250 ... 1950 mm
Resistance tolerance	± 20
Load resistance	100 kOhm min.
Recommended cursor current	< 1 μ A
Permissible applied voltage	28 VDC max.
Electrical connections	4 pin connector
Displacement speed	< 1,5 m/s
Mechanical life	100 million movement
Case dimensions	33 mm x 33 mm
Case material	Anodized aluminium
Mechanical fixing	Variable brackets
IP degree	IP 40 (if mounted upside down IP 53)
Operating temperature	-20°C ... +80°C
Storage temperature	-30°C ... +90°C

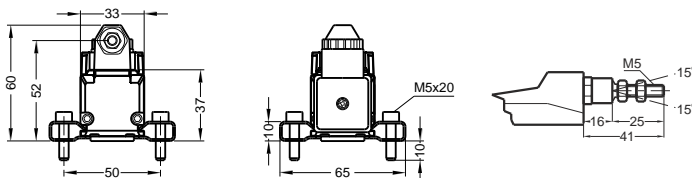
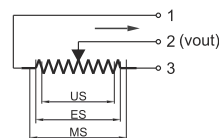
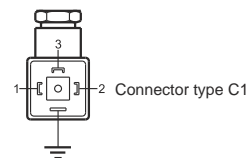
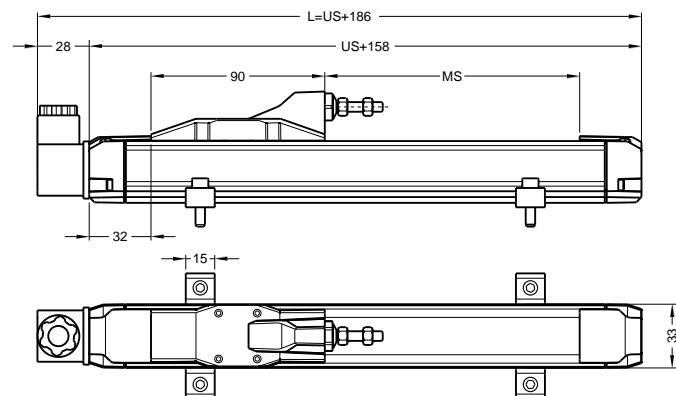

LPH (mm)	100	125	130	150	175	200	225	250	275	300	325	350	375	400	450	500	550	600	650	700	750	800	850	900	1000	1250	1500	1750	1950
US (Useful Stroke)	100	125	130	150	175	200	225	250	275	300	325	350	375	400	450	500	550	600	650	700	750	800	850	900	1000	1250	1500	1750	1950
MS (Mechanical Stroke)	104	129	134	154	179	204	229	254	279	304	329	354	379	404	454	504	554	604	654	704	754	804	854	904	1004	1254	1504	1754	1954
L (Total Length)	271	296	301	321	346	371	396	421	446	471	496	521	546	571	621	671	721	771	821	871	921	971	1021	1071	1171	1421	1671	1921	2121

Model	Measurement stroke (mm)	Linearity (%)	Resistance (KOhm)	Connector / Cable
(example) RPH	500	D	5K	C1
RPH	100 ... 1950 mm	D: $\pm 0,05$ (>200 mm), $\pm 0,1$ (130 - 200 mm), $\pm 0,2$ (75 - 130 mm), $\pm 0,5$ (<75 mm)	5K: 5 KOhm 10K: 10 KOhm 20K: 20 KOhm	C1: 4 pin connector

Linear Potentiometer

Measuring range 50 - 1000 mm
 Long mechanical life 100 million movement
 Excellent repeatability <0.01 mm
 Infinite resolution
 5 kOhm : 50 ... 600 mm
 10 kOhm : 650 ... 1000 mm



Technical specifications

Measurement stroke	50 to 1000 mm
Linearity	$\pm 0,05$ (>200 mm), $\pm 0,1$ (130 - 200 mm), $\pm 0,2$ (75 - 130 mm), $\pm 0,5$ (<75 mm)
Repeatability	< 0.01 mm
Resolution	Infinite
Resistance	5 kOhm : 50 ... 600 mm 10 kOhm : 650 ... 1000 mm
Resistance tolerance	± 20
Load resistance	100 kOhm min.
Recommended cursor current	<1 μ A
Permissible applied voltage	28 VDC max.
Displacement speed	< 5 m/s
Mechanical life	100 million movement
Case dimensions	21,5 mm x 10 mm
Case material	Anodized aluminium
Mechanical fixing	Variable brackets
IP degree	IP 65
Operating temperature	-20°C ... +80°C
Storage temperature	-30°C ... +90°C

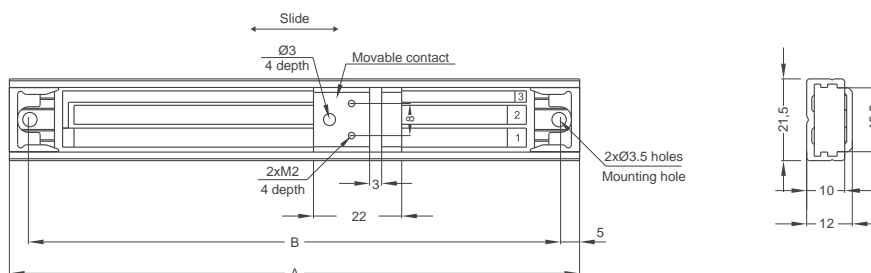

OPH (mm)	50	100	150	200	250	300	350	400	450	500	550	600	650	700	750	800	850	900	1000
A ± 1	100	150	200	250	300	350	400	450	500	550	600	650	700	750	800	850	900	950	1050
B $\pm 0,5$	90	140	190	240	290	340	390	440	490	540	590	640	690	740	790	840	890	940	1040

Model	Measurement stroke (mm)	Linearity (%)	Resistance (KOhm)
(example) OPH	500	D	5K
OPH	50 ... 1000 mm	D: $\pm 0,05$ (>200 mm), $\pm 0,1$ (130 - 200 mm), $\pm 0,2$ (75 - 130 mm), $\pm 0,5$ (<75 mm)	5K: 5 kOhm 10K: 10 kOhm

Linear Potentiometer

Measuring range 50 - 800 mm
 Long mechanical life 100 million movements
 Excellent repeatability <0.01 mm
 Infinite resolution
 5 kOhm : 50 ... 600 mm
 10 kOhm : 650 ... 800 mm



Technical specifications

Measurement stroke	50 to 800 mm
Linearity	± %0,05 (>200 mm), ±%0,1 (130 - 200 mm), ±%0,2 (75 - 130 mm), ±%0,5 (<75 mm)
Repeatability	< 0,01 mm
Resolution	Infinite
Resistance	5 kOhm : 50 ... 600 mm 10 kOhm : 650 ... 800 mm
Resistance tolerance	± %20
Load resistance	100 kOhm min.
Recommended cursor current	<1 µA
Permissible applied voltage	28 VDC max.
Electrical connections	4 pin connector (standard), cable (optional)
Displacement speed	< 5 m/s
Mechanical life	100 million movement
Case dimensions	Ø38 mm
Case material	Anodized aluminium
Rod material	Stainless steel
Rod diameter	Ø10 mm
Mechanical fixing	Ball joints on the both sides
IP degree	IP 65
Operating temperature	-20°C ... +80°C
Storage temperature	-30°C ... +90°C

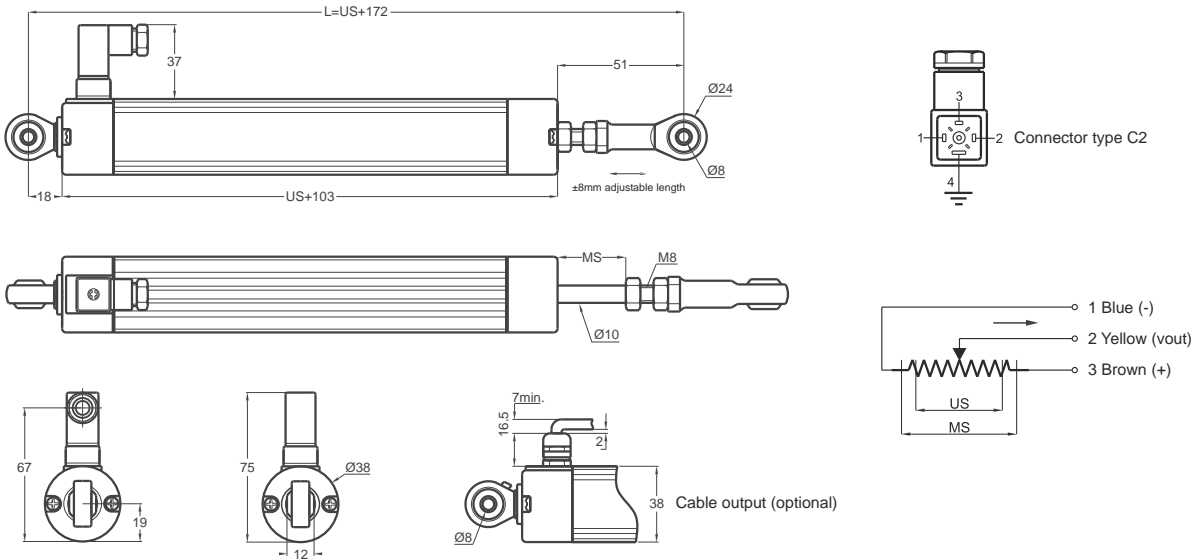

LPC (mm)	50	75	100	125	130	150	175	200	225	250	275	300	325	350	375	400	450	500	550	600	650	700	800
US (Usefull Stroke)	50	75	100	125	130	150	175	200	225	250	275	300	325	350	375	400	450	500	550	600	650	700	800
MS (Mechanical Stroke)	54	79	104	129	134	154	179	204	229	254	279	304	329	354	379	404	454	504	554	604	654	704	804
L (Total Length)	222	247	272	297	302	322	347	372	397	422	447	472	497	522	547	572	622	672	722	772	822	872	972

Model	Measurement stroke (mm)	Linearity (%)	Resistance (KOhm)	Connector / Cable
(example) LPC	500	D	5K	C2
LPC	50 ... 800 mm	D: ±%0,05 (>200 mm), ±%0,1 (130 - 200 mm), ±%0,2 (75 - 130 mm), ±%0,5 (<75 mm)	5K: 5 kOhm 10K: 10 kOhm	C2 : 4 pin connector 1M : 1 meter cable 2M5: 2,5 meter cable

Linear Potentiometer

Measuring range 25 - 400 mm
 Long mechanical life 100 million movements
 Excellent repeatability <0.01 mm
 2 kOhm : 25 ... 50 mm
 5 kOhm : 75 ... 400 mm



Technical specifications

Measurement stroke	25 to 400 mm
Linearity	± %0,05 (>200 mm), ±%0,1 (130 - 200 mm), ±%0,2 (75 - 130 mm), ±%0,5 (<75 mm)
Repeatability	< 0,01 mm
Resolution	Infinite
Resistance	2 kOhm : 25 ... 50 mm 5 kOhm : 75 ... 400 mm
Resistance tolerance	± %20
Load resistance	100 kOhm min.
Recommended cursor current	<1 µA
Permissible applied voltage	28 VDC max.
Electrical connections	1 m cable (standard)
Displacement speed	< 5 m/s
Mechanical life	100 million movement
Case dimensions	Ø25 mm
Case material	Anodized aluminium
Rod material	Stainless steel
Rod diameter	Ø5 mm
IP degree	IP 65
Operating temperature	-20°C ... +80°C
Storage temperature	-30°C ... +90°C

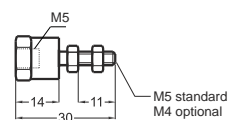
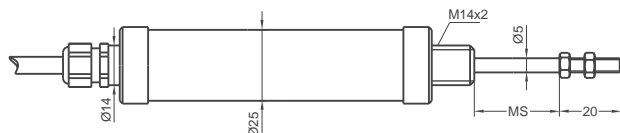
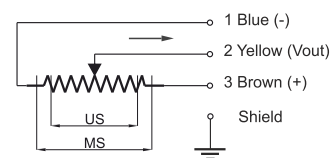
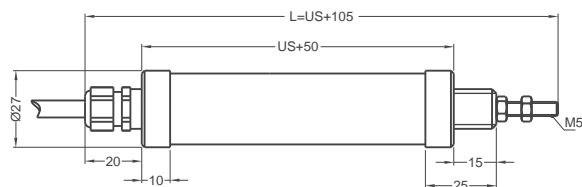

LSC(mm)	25	50	75	100	125	150	175	200	250	300	350	400
US (Usefull Stroke)	25	50	75	100	125	150	175	200	250	300	350	400
MS (Mechanical Stroke)	28	53	78	103	128	153	178	203	253	303	353	403
L (Total Length)	130	155	180	205	230	255	280	305	355	405	455	505

Model	Measurement stroke (mm)	Linearity (%)	Resistance (kOhm)	Connector / Cable
(example) LSC	175	D	5K	1M
LSC	25 ... 400 mm	D: ±%0,05 (>200 mm), ±%0,1 (130 - 200 mm), ±%0,2 (75 - 130 mm), ±%0,5 (<75 mm)	2K: 2 kOhm 5K: 5 kOhm	1M : 1 meter cable (standard) 1M5: 1,5 meter cable 2M5: 2,5 meter cable

Linear Potentiometer

Measuring range 50 - 600 mm
 Long mechanical life 100 million movements
 Excellent repeatability <0.01 mm
 Infinite resolution
 5 kOhm: 50 ... 600 mm



Technical specifications

Measurement stroke	50 to 600 mm
Linearity	± %0,05 (>200 mm), ±%0,1 (130 - 200 mm), ±%0,2 (75 - 130 mm), ±%0,5 (<75 mm)
Repeatability	< 0.01 mm
Resolution	Infinite
Resistance	5 kOhm: 50 ... 600 mm
Resistance tolerance	± %20
Load resistance	100 kOhm min.
Recommended cursor current	<1 µA
Permissible applied voltage	28 VDC max.
Electrical connections	4 pin connector (standard), cable (optional)
Displacement speed	< 5 m/s
Mechanical life	100 million movement
Case dimensions	33 mm x 33 mm
Case material	Anodized aluminium
Rod material	Stainless steel
Rod diameter	Ø6 mm
Mechanical fixing	Ball joints on the both sides
IP degree	IP 65
Operating temperature	-20°C ... +80°C
Storage temperature	-30°C ... +90°C

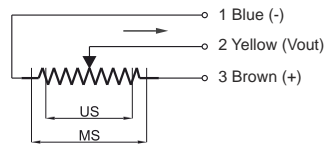
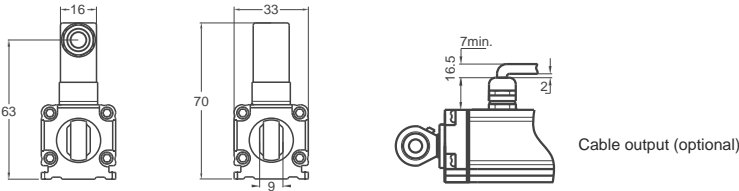
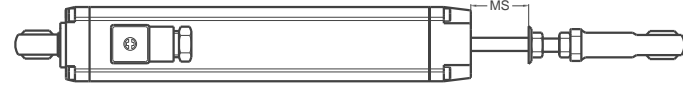
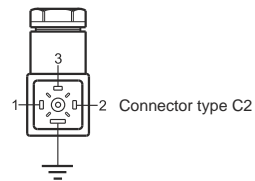
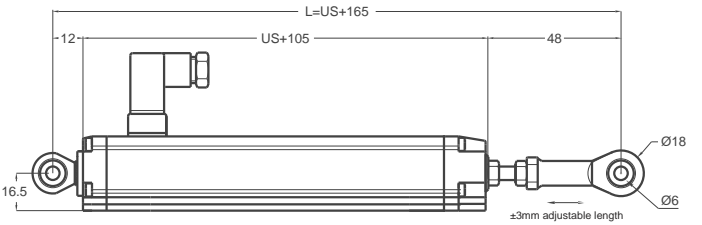

RTM (mm)	50	75	100	125	130	150	175	200	225	250	275	300	325	350	375	400	450	500	550	600
US (Usefull Stroke)	50	75	100	125	130	150	175	200	225	250	275	300	325	350	375	400	450	500	550	600
MS (Mechanical Stroke)	54	79	104	129	134	154	179	204	229	254	279	304	329	354	379	404	454	504	554	604
L (Total Length)	215	240	265	290	295	315	340	365	390	415	440	465	490	515	540	565	615	665	715	765

Model	Measurement stroke (mm)	Linearity (%)	Resistance (kOhm)	Connector / Cable
(example) RTM	500	D	5K	C2
RTM	50 ... 600 mm	D: ±%0,05 (>200 mm), ±%0,1 (130 - 200 mm), ±%0,2 (75 - 130 mm), ±%0,5 (<75 mm)	5K: 5 kOhm	C2 : 4 pin connector (standard) 1M : 1 meter cable 2M5: 2,5 meter cable

Linear Potentiometer

- Measuring range 30 - 1000 mm
- Long mechanical life 100 million movements
- Excellent repeatability <0.01 mm
- Infinite resolution
- 5 kOhm : 30 ... 600 mm
- 10 kOhm : 650 ... 1000 mm



Technical specifications

Measurement stroke	30 to 1000 mm
Linearity	± %0,05 (>200 mm), ±%0,1 (130 - 200 mm), ±%0,2 (75 - 130 mm), ±%0,5 (<75 mm)
Repeatability	< 0.01mm
Resolution	Infinite
Resistance	5 kOhm : 30 ... 600 mm 10 kOhm : 650 ... 1000 mm
Resistance tolerance	± %20
Load resistance	100 kOhm min.
Recommended cursor current	<1 µA
Permissible applied voltage	28 VDC max.
Electrical connections	1 m cable (standard)
Displacement speed	< 5 m/s
Mechanical life	100 million movement
Case dimensions	33 mm x 33 mm
Case material	Anodized aluminium
Rod material	Stainless steel
Rod diameter	Ø6 mm
Mechanical fixing	Variable brackets
IP degree	IP 65
Operating temperature	-20°C ... +80°C
Storage temperature	-30°C ... +90°C

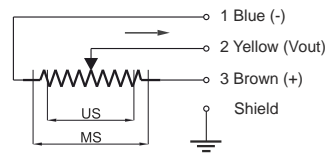
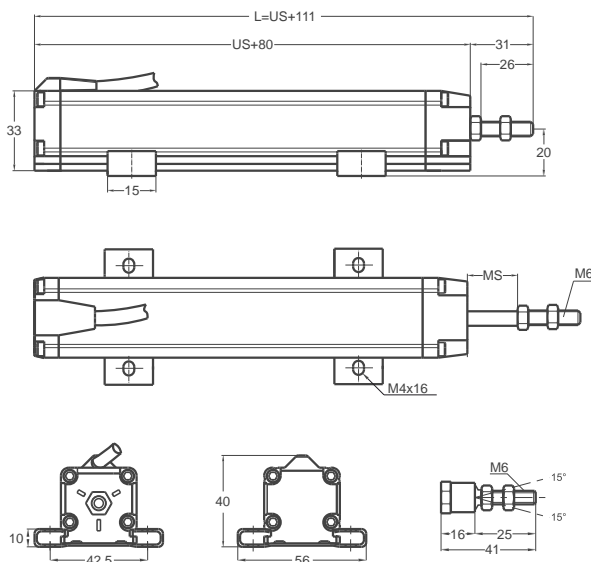

RTK (mm)	30	50	75	100	125	130	150	175	200	225	250	275	300	325	350	375	400	450	500	550	600	650	700	750	800	850	900	1000
US (Usefull Stroke)	30	50	75	100	125	130	150	175	200	225	250	275	300	325	350	375	400	450	500	550	600	650	700	750	800	850	900	1000
MS (Mechanical Stroke)	34	54	79	104	129	133	153	178	203	228	253	278	303	328	353	373	403	453	503	553	603	653	703	753	803	853	903	1003
L (Total Length)	141	161	186	211	236	241	261	286	311	336	361	386	411	436	461	486	511	561	611	661	711	761	811	861	911	961	1011	1111

Model	Measurement stroke (mm)	Linearity (%)	Resistance (kOhm)	Connector / Cable
(example) RTK	500	D	5K	1M
RTK	30 ... 1000 mm	D: ±%0,05 (>200 mm) ±%0,1 (130 - 200 mm) ±%0,2 (75 - 130 mm) ±%0,5 (<75 mm)	5K: 5 kOhm 10K: 10 kOhm	1M : 1 meter cable (standard) 2M5: 2,5 meter cable

Linear Potentiometer Spring Return

Measuring range 30 - 150 mm
 Long mechanical life 100 million movements
 Excellent repeatability <0.01 mm
 Infinite resolution
 5 kOhm: 30 ... 150 mm



Technical specifications

Measurement stroke	30 to 150 mm
Linearity	±%0,1 (130 - 200 mm), ±%0,2 (75 - 130 mm), ±%0,5 (<75 mm)
Repeatability	< 0,01 mm
Resolution	Infinite
Resistance	5 kOhm: 30 ... 150 mm
Resistance tolerance	± %20
Load resistance	100 kOhm min.
Recommended cursor current	<1 µA
Permissible applied voltage	28 VDC max.
Electrical connections	4 pin connector
Displacement speed	< 5 m/s
Mechanical life	100 million movement
Case dimensions	33 mm x 33 mm
Case material	Anodized aluminium
Rod material	Stainless steel
Rod diameter	Ø6 mm
Mechanical fixing	Variable brackets
IP degree	IP 54
Operating temperature	-20°C ... +80°C
Storage temperature	-30°C ... +90°C

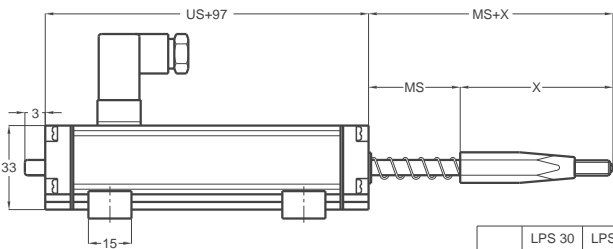

	LPS 30	LPS 50	LPS 75	LPS 100	LPS 150
X	63 mm	68 mm	78 mm	88 mm	108 mm

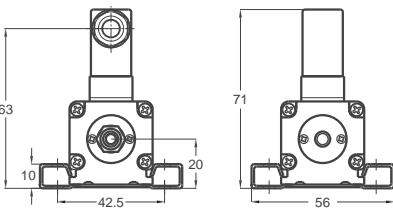
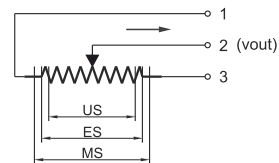
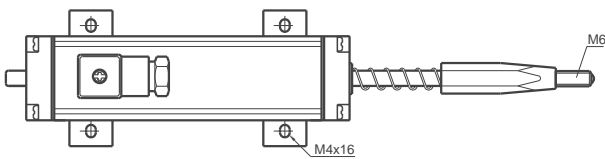
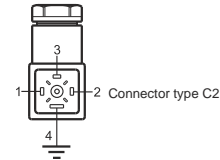

LPS(mm)	30	50	75	100	125	150
US (Usefull Stroke)	30	50	75	100	125	150
MS (Mechanical Stroke)	34	54	79	104	129	154
L (Total Length)	227	272	332	392	452	512

Model	Measurement stroke (mm)	Linearity (%)	Resistance (KOhm)	Connector / Cable
(example) LPS	100	D	5K	C2
LPS	30 ... 150 mm	D: ±%0,05 (>200 mm) ±%0,1 (130 - 200 mm) ±%0,2 (75 - 130 mm) ±%0,5 (<75 mm)	5K: 5 kOhm	C2: 4 pin connector

Hydraulic In-Cylinder Linear Potentiometer

Single sensor or double sensor for redundancy
 Measuring range 100 - 1000 mm
 20 million movements
 <0.01 mm repeatability
 Infinite resolution
 5 kOhm : 100 ... 600 mm
 10 kOhm : 650 ... 1000 mm



S model
Single sensor

R model
Double sensor

Technical specifications

Measurement stroke	100 to 1000 mm
Linearity	± %1.0
Repeatability	< 0.2 mm
Resolution	Infinite
Resistance	5 kOhm: 100 ... 600 mm 10 kOhm: 650 ... 1000 mm
Resistance tolerance	± %20
Load resistance	100 kOhm min.
Recommended cursor current	< 1 µA
Permissible applied voltage	28 VDC max.
Displacement speed	< 2 m/s
Mechanical life	> 20 million movement
Case dimensions	Ø15
Case material	Anodized aluminium
Flange material	Stainless steel (AISI303)
Operating temperature	-20°C ... +80°C
Storage temperature	-30°C ... +90°C

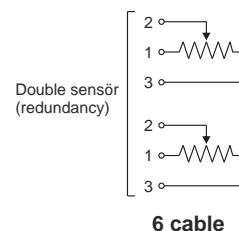
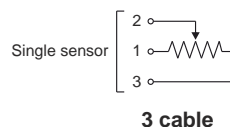
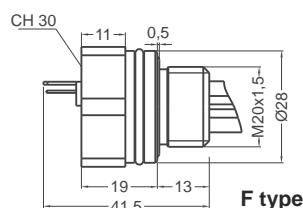
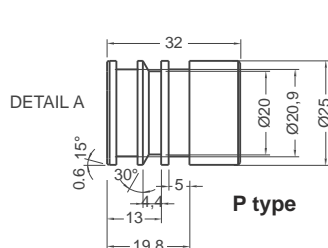
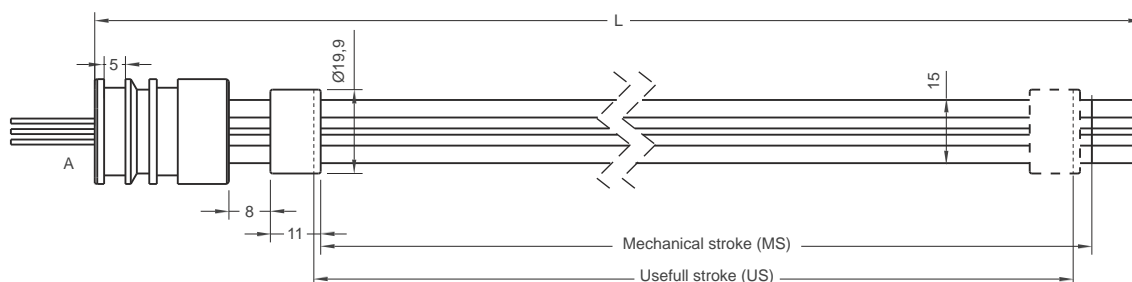

RHTF / RHTP (mm)	100	150	200	250	300	350	400	450	500	550	600	650	700	750	800	850	900	950	1000
US (Usefull stroke)	100	150	200	250	300	350	400	450	500	550	600	650	700	750	800	850	900	900	900
MS ±0,5 (Mechanical stroke)	104	154	204	254	304	354	404	454	504	554	604	654	704	754	804	854	904	904	904
RHTF L (Total length)	157	207	257	307	357	407	457	507	557	607	657	707	757	807	857	907	957	1007	1057
RHTP L (Total length)	166	216	266	316	366	416	466	516	566	616	666	716	766	816	866	916	966	1016	1066

Model	Output type	Measurement stroke (mm)	Linearity (%)	Resistance (kOhm)
(example) RHTF	-S	500	D	5K
RHTF (Flange type) RHTP (Piston type)	-S : Single sensor -R : Double sensor (redundancy)	100 ... 1000 mm	D: ± %0,05	5K: 5 kOhm 10K: 10 kOhm

Linear Potentiometers
 Linear Potentiometers Slim Body Series
 Linear Potentiometers Conditioner Circuit
 Magnetostrictive Position Sensors
 Magnetic Linear Incremental Encoders
 Draw Wire Potentiometers/Encoders
 Optic Rotary Absolute Encoders
 Magnetic Rotary Encoders
 Optic Rotary Incremental Encoders

Linear Potentiometer Slim Body Series

Measuring range 10 - 400 mm
 Long mechanical life
 Excellent repeatability <0.01 mm
 Infinite resolution
 2 kOhm : 10 ... 50 mm
 5 kOhm : 75 ... 400 mm



Technical specifications

Measurement stroke	10 to 400 mm
Linearity	±%0,05 (>200 mm), ±%0,1 (130 - 200 mm), ±%0,2 (75 - 130 mm), ±%0,5 (<75 mm)
Repeatability	< 0.01 mm
Resolution	Infinite
Resistance	2 kOhm: 10 ... 50 mm 5 kOhm: 75 ... 400 mm
Resistance tolerance	± %20
Load resistance	100 kOhm min.
Recommended cursor current	<1 µA
Permissible applied voltage	28 VDC max.
Electrical connections	Connector or 1 m cable output
Displacement speed	< 5 m/s
Mechanical life	100 million movement
Case dimensions	Ø18 mm
Case material	Anodized aluminium
Rod material	Stainless steel
Rod diameter	Ø5 mm
Mechanical fixing	Variable brackets
IP degree	IP 65
Operating temperature	-20°C ... +80°C
Storage temperature	-30°C ... +90°C

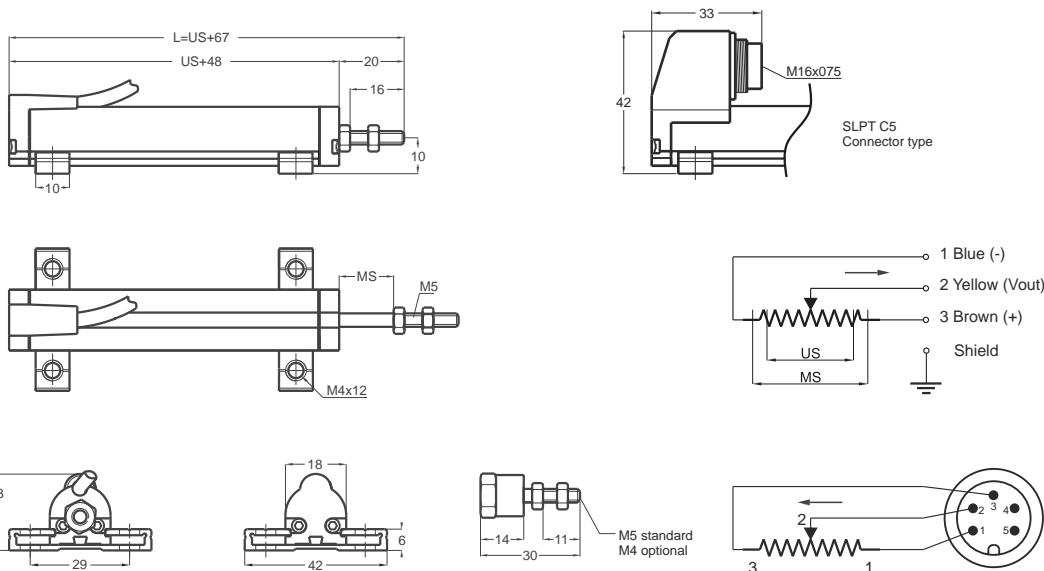

SLPT(mm)	10	25	50	75	100	125	150	175	200	250	300	350	400
US (Usefull Stroke)	10	25	50	75	100	125	150	175	200	250	300	350	400
MS (Mechanical Stroke)	13	28	53	78	103	128	153	178	203	253	303	353	403
L (Total Length)	78	93	118	143	168	193	218	243	268	318	368	418	468

Model	Measurement stroke (mm)	Linearity (%)	Resistance (kOhm)	Connector / Cable
(example) SLPT	175	D	5K	1M
SLPT	10 ... 400 mm	D: ±%0,05 (>200 mm) ±%0,1 (130 - 200 mm) ±%0,2 (75 - 130 mm) ±%0,5 (<75 mm)	2K: 2 kOhm 5K: 5 kOhm	1M : 1 meter cable (standard) 1M5: 1,5 meter cable 2M : 2 meter cable C5 : Connector

Linear Potentiometer Slim Body Series

Measuring range 10 - 400 mm
 Long mechanical life
 Excellent repeatability <0.01 mm
 Infinite resolution
 2 kOhm : 10 ... 50 mm
 5 kOhm : 75 ... 400 mm

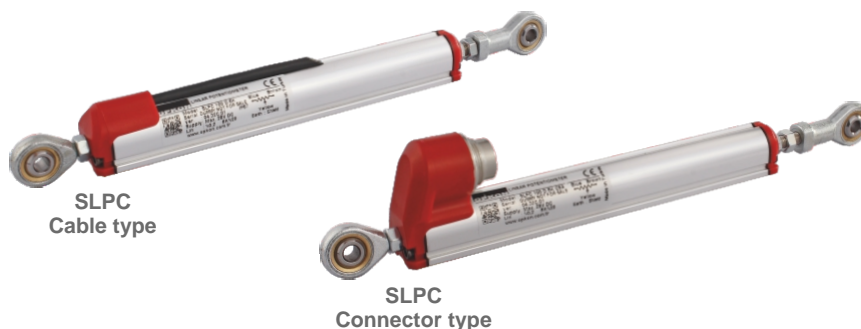

Technical specifications

Measurement stroke	10 to 400 mm
Linearity	± %0,05 (>200 mm), ±%0,1 (130 - 200 mm), ±%0,2 (75 - 130 mm), ±%0,5 (<75 mm)
Repeatability	< 0,01 mm
Resolution	Infinite
Resistance	2 kOhm : 10 ... 50 mm 5 kOhm : 75 ... 400 mm
Resistance tolerance	± %20
Load resistance	100 kOhm min.
Recommended cursor current	<1 µA
Permissible applied voltage	28 VDC max.
Electrical connections	Connector or 1 m cable output
Displacement speed	< 5 m/s
Mechanical life	100 million movement
Case dimensions	Ø18 mm
Case material	Anodized aluminium
Rod material	Stainless steel
Rod diameter	Ø5 mm
Mechanical fixing	Ball joints on the both sides
IP degree	IP 65
Operating temperature	-20°C ... +80°C
Storage temperature	-30°C ... +90°C

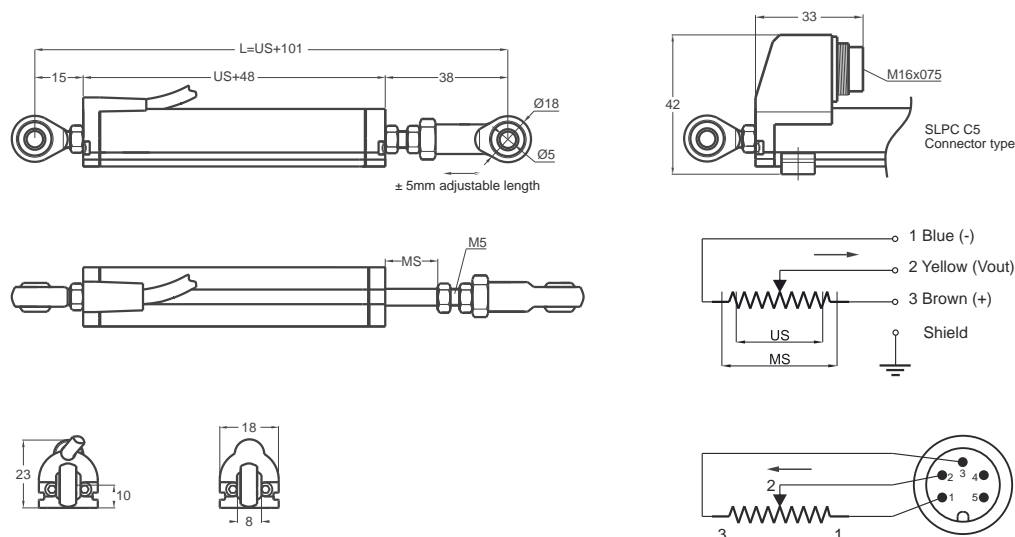

SLPC(mm)	10	25	50	75	100	125	150	175	200	250	300	350	400
US (Usefull Stroke)	10	25	50	75	100	125	150	175	200	250	300	350	400
MS (Mechanical Stroke)	13	28	53	78	103	128	153	178	203	253	303	353	403
L (Total Length)	111	126	151	176	201	226	251	276	301	351	401	451	501

Model	Measurement stroke (mm)	Linearity (%)	Resistance (KOhm)	Connector / Cable
(example) SLPC	175	D	5K	1M
SLPC	10 ... 400 mm	D: ±%0,05 (>200 mm) ±%0,1 (130 - 200 mm) ±%0,2 (75 - 130 mm) ±%0,5 (<75 mm)	2K: 2 kOhm 5K: 5 kOhm	1M : 1 meter cable (standard) 1M5: 1,5 meter cable 2M : 2 meter cable C5 : Connector

Linear Potentiometers
 Linear Potentiometers Slim Body Series
 Linear Potentiometers Conditioner Circuit
 Magnetostrictive Position Sensors
 Magnetic Linear Incremental Encoders
 Draw Wire Potentiometers/Encoders
 Optic Rotary Absolute Encoders
 Magnetic Rotary Encoders
 Optic Rotary Incremental Encoders

Linear Potentiometer Spring Return, Slim Body Series

Measuring range 10 - 100 mm
 Long mechanical life
 Excellent repeatability <0.01 mm
 Infinite resolution
 2 kOhm : 10 ... 50 mm
 5 kOhm : 75 ... 100 mm



Technical specifications

Measurement stroke	10 to 100 mm
Linearity	±%0,2 (75 - 130 mm), ±%0,5 (<75 mm)
Repeatability	< 0.01 mm
Resolution	Infinite
Resistance	2 kOhm : 10 ... 50 mm 5 kOhm : 75 ... 100 mm
Resistance tolerance	± %20
Load resistance	100 kOhm min.
Recommended cursor current	<1 µA
Permissible applied voltage	28 VDC max.
Electrical connections	Connector or 1 m cable output
Displacement speed	< 5 m/s
Mechanical life	100 million movement
Case dimensions	Ø18 mm
Case material	Anodized aluminium
Rod material	Stainless steel
Rod diameter	Ø5 mm
Mechanical fixing	Variable brackets
IP degree	IP 65
Operating temperature	-20°C ... +80°C
Storage temperature	-30°C ... +90°C

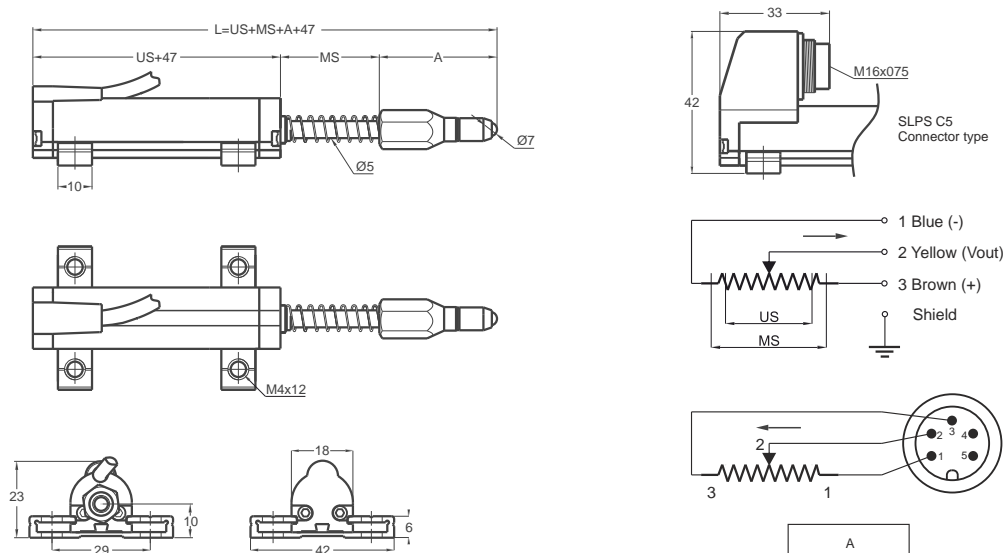

SLPS(mm)	10	25	50	75	100
US (Usefull Stroke)	10	25	50	75	100
MS (Mechanical Stroke)	13	28	53	78	103
L (Total Length)	105	135	192	242	292

A	
SLPS 10	35
SLPS 25	35
SLPS 50	42
SLPS 75	42
SLPS 100	42

Model	Measurement stroke (mm)	Linearity (%)	Resistance (kOhm)	Connector / Cable
(example) SLPS	100	D	5K	1M
SLPS	10 ... 100 mm	D: ±%0,2 (75 - 130 mm) ±%0,5 (<75 mm)	2K: 2 kOhm 5K: 5 kOhm	1M : 1 meter cable (standard) 1M5: 1,5 meter cable 2M : 2 meter cable C5 : Connector

Linear Potentiometer Internal Spring Return, Slim Body Series

- Measuring range 10 - 100 mm
- Long mechanical life
- Excellent repeatability <0.01 mm
- Infinite resolution
- 2 kOhm: 10 ... 50 mm
- 5 kOhm: 75 ... 100 mm



Technical specifications

Measurement stroke	10 to 100 mm
Linearity	±%0,2 (75-100 mm), ±%0,5 (<75 mm)
Repeatability	< 0,01 mm
Resolution	Infinite
Resistance	2 kOhm: 10 ... 50 mm 5 kOhm: 75 ... 100 mm
Resistance tolerance	± %20
Recommended cursor current	<1 µA
Electrical connections	Connector or 1 m cable output
Displacement speed	< 5 m/s
Mechanical life	100 million movement
Case dimensions	Ø18 mm
Case material	Anodized aluminium
Rod material	Stainless steel
Rod diameter	Ø5 mm
Mechanical fixing	Variable brackets
IP degree	IP 65
Operating temperature	-20°C ... +80°C
Storage temperature	-30°C ... +90°C

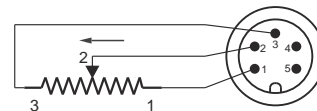
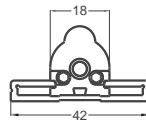
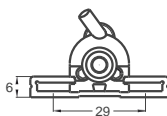
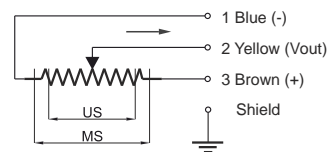
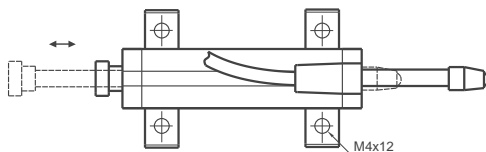
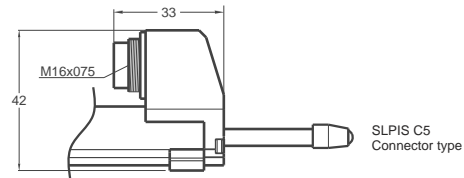
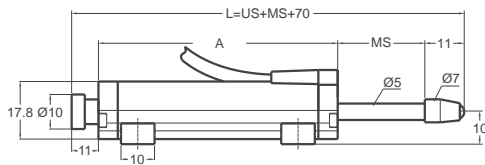

SLPIS (mm)	10	25	50	75	100
US (Usefull Stroke)	10	25	50	75	100
MS (Mechanical Stroke)	13	28	53	78	103
L (Total Length)	93	123	179	235	288

A	
SLPIS 10	58
SLPIS 25	73
SLPIS 50	104
SLPIS 75	135
SLPIS 100	163

Model	Measurement stroke (mm)	Linearity (%)	Resistance (kOhm)	Connector / Cable
(example) SLPIS	25	D	5K	1M
SLPIS	10 ... 100 mm	D: ±%0,5 (<75 mm)	2K: 2 kOhm 5K: 5 kOhm	1M: 1 meter cable (standard) C5: Connector

Linear Potentiometer Spring Return, Slim Body Series

Measuring range 10 - 100 mm
 Long mechanical life
 Excellent repeatability <0.01 mm
 Infinite resolution
 2 kOhm : 10 ... 50 mm
 5 kOhm : 75 ... 100 mm



Technical specifications

Measurement stroke	10 to 100 mm
Linearity	±%0,2 (75 - 130 mm), ±%0,5 (>75 mm)
Repeatability	< 0.01 mm
Resolution	Infinite
Resistance	2 kOhm : 10 ... 50 mm 5 kOhm : 75 ... 100 mm
Resistance tolerance	± %20
Load resistance	100 kOhm min.
Recommended cursor current	<1 µA
Permissible applied voltage	28 VDC max.
Electrical connections	Connector or 1 m cable output
Displacement speed	< 5 m/s
Mechanical life	100 million movement
Case dimensions	Ø18 mm
Case material	Anodized aluminium
Rod material	Stainless steel
Rod diameter	Ø5 mm
Mechanical fixing	Variable brackets
IP degree	IP 65
Operating temperature	-20°C ... +80°C
Storage temperature	-30°C ... +90°C

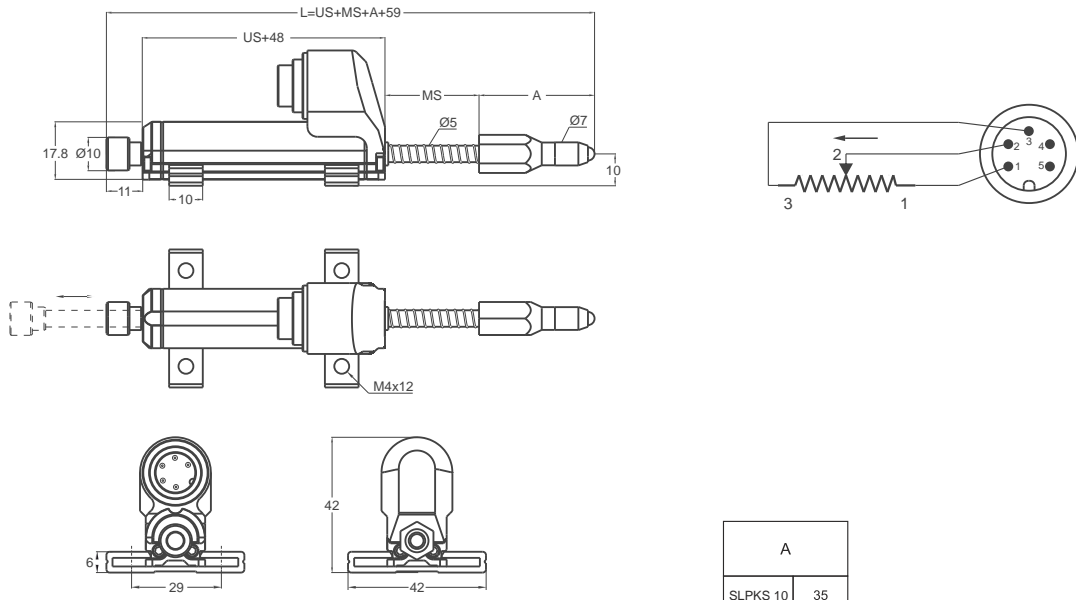

SLPKS(mm)	10	25	50	75	100
US (Usefull Stroke)	10	25	50	75	100
MS (Mechanical Stroke)	13	28	53	78	103
L (Total Length)	117	147	204	254	304

A	
SLPKS 10	35
SLPKS 25	35
SLPKS 50	42
SLPKS 75	42
SLPKS 100	42

Model	Measurement stroke (mm)	Linearity (%)	Resistance (kOhm)	Connector / Cable
(example) SLPKS	100	D	5K	C5
SLPKS	10 ... 100 mm	D: ± %0,2 (75 - 130 mm) ± %0,5 (<75 mm)	2K: 2 kOhm 5K: 5 kOhm	1M: 1 meter cable (standard) C5: Connector

Linear Potentiometer Slim Body Series

Measuring range 10 - 200 mm
 Long mechanical life
 Excellent repeatability <0.01mm
 Infinite resolution
 2 kOhm: 10 ... 50 mm
 5 kOhm: 75 ... 200 mm



Technical specifications

Measurement stroke	10 to 200 mm
Linearity	±%0,1 (130 - 200 mm), ±%0,2 (75 - 130 mm), ±%0,5 (<75 mm)
Repeatability	< 0.01 mm
Resolution	Infinite
Resistance	2 kOhm: 10 ... 50 mm 5 kOhm: 75 ... 200 mm
Resistance tolerance	± %20
Load resistance	100 kOhm min.
Recommended cursor current	< 1 µA
Permissible applied voltage	28 VDC max.
Electrical connections	Connector or 1 m cable output
Displacement speed	< 5m/s
Mechanical life	100 million movement
Case dimensions	Ø18 mm
Case material	Anodized aluminium
Rod diameter	Ø5 mm
Rod material	Stainless steel
Mechanical fixing	Variable brackets
IP degree	IP 65
Operating temperature	-20°C ... +80°C
Storage temperature	-30°C ... +90°C

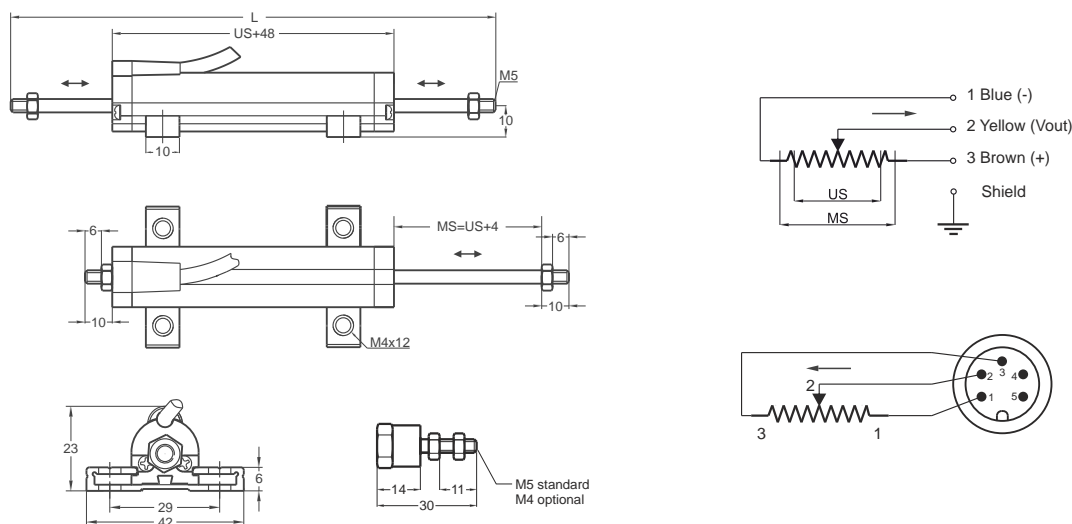

SLPK(mm)	10	25	50	75	100	125	150	175	200
US (Usefull Stroke)	10	25	50	75	100	125	150	175	200
MS (Mechanical Stroke)	14	29	54	79	104	129	154	179	204
L (Total Length)	92	122	172	222	272	322	372	422	472

Model	Measurement stroke (mm)	Linearity (%)	Resistance (kOhm)	Connector / Cable
(example) SLPK	150	D	5K	1M
SLPK	10 ... 200 mm	D: ±%0,1 (130 - 200 mm) ±%0,2 (75 - 130 mm) ±%0,5 (<75 mm)	2K: 2 kOhm 5K: 5 kOhm	1M : 1 meter cable (standard) 1M5: 1,5 meter cable 2M : 2 meter cable C5 : Connector

Linear Potentiometer Ultra Slim Body Series

Measuring range 10 - 25 mm
 Long mechanical life
 Excellent repeatability <0.01 mm
 Infinite resolution
 2 kOhm: 10 ... 25 mm



Technical specifications

Measurement stroke	10 to 25 mm
Linearity	±%0,5 (<75 mm)
Repeatability	< 0.01 mm
Resolution	Infinite
Resistance	2 kOhm: 10 ... 25 mm
Resistance tolerance	± %20
Load resistance	100 kOhm min.
Recommended cursor current	<1 µA
Permissible applied voltage	28 VDC max.
Electrical connections	Cable output
Displacement speed	< 5 m/s
Mechanical life	50 million movement
Case dimensions	13x16 mm
Case material	Anodized aluminium
Rod material	Stainless steel
Rod diameter	Ø4 mm
Mechanical fixing	Screws
IP degree	IP 54
Operating temperature	-20°C ... +80°C
Storage temperature	-30°C ... +90°C

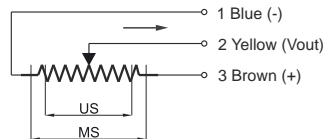
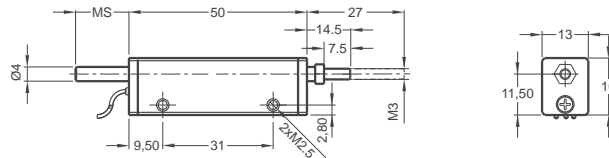

LMT(mm)	10	14	25
US (Usefull Stroke)	10	14	25
MS (Mechanical Stroke)	12	16	27
L (Total Length)	69	77	89

Model	Measurement stroke (mm)	Linearity (%)	Resistance (kOhm)	Connector / Cable
(example) LMT	25	D	2K	0M15
LMT	10 ... 25 mm	D: ±%0,5 (<75 mm)	2K: 2 kOhm	0M15: 0,15 meter cable (standard) 1M : 1 meter cable

Linear Potentiometer Internal Voltage / Current Conditioner Circuit

Internal electronic circuit
 Measuring range 30 - 1000 mm
 Output 4-20 mA, 0-20 mA, 0-10 V
 20-4 mA, 20-0 mA, 10-0 V
 Very stable output signal
 Best solution for automation systems
 Excellent repeatability



Technical specifications

Measurement stroke	30 to 1000 mm
Linearity	± %0,05 (>200 mm), ±%0,1 (130 - 200 mm), ±%0,2 (75 - 130 mm), ±%0,5 (<75 mm)
Repeatability	< 0.01 mm
Resolution	Infinite
Output	4-20 mA, 0-20 mA, 0-10 V / 20-4 mA, 20-0 mA, 10-0 V
Permissible applied voltage	15 - 30 VDC
Electrical connections	4 pin connector
Displacement speed	< 5 m/s
Mechanical life	100 million movement
Case dimensions	33 mm x 33 mm
Case material	Anodized aluminium
Rod diameter	Ø6 mm
Rod material	Stainless steel
Mechanical fixing	Variable brackets
IP degree	IP 65
Operating temperature	-20°C ... +80°C
Storage temperature	-30°C ... +90°C

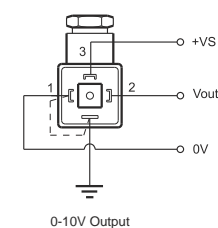
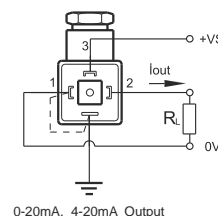
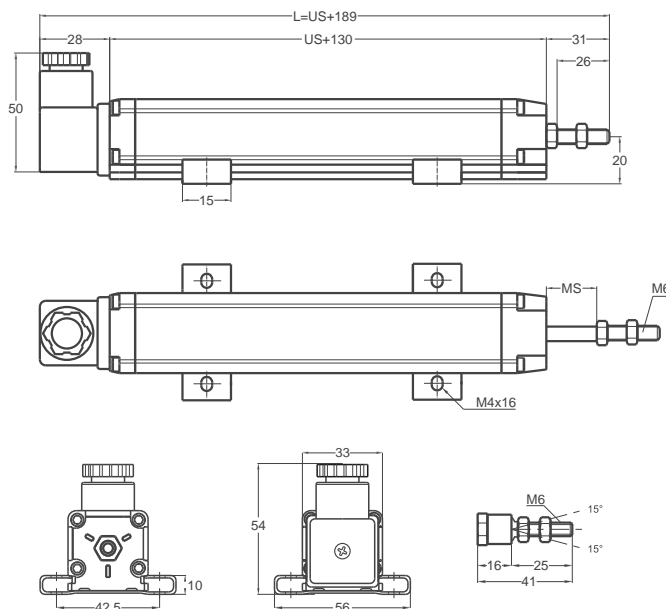

ERTL (mm)	30	50	75	100	125	130	150	175	200	225	250	275	300	325	350	375	400	450	500	550	600	650	700	750	800	850	900	1000
US (Usefull Stroke)	30	50	75	100	125	130	150	175	200	225	250	275	300	325	350	375	400	450	500	550	600	650	700	750	800	850	900	1000
MS (Mechanical Stroke)	33	53	78	103	128	133	153	178	203	228	253	278	303	328	353	378	403	453	503	553	603	653	703	753	803	853	903	1003
L (Total Length)	219	239	264	289	314	319	339	364	389	414	439	464	489	514	539	564	589	639	689	739	789	839	889	939	989	1039	1089	1189

Model	Measurement stroke (mm)	Linearity (%)	Output	Connector / Cable
(example) ERTL	500	D	V10	C1
ERTL	30 ... 1000 mm	D: ±%0,05 (>200 mm) ±%0,1 (130 - 200 mm) ±%0,2 (75 - 130 mm) ±%0,5 (<75 mm)	I40: 4 - 20 mA V10: 0 - 10 V I04: 20-4 mA V01: 10-0 V I20: 0 - 20 mA I02: 20-0 mA	C1: 4 pin connector

Linear Potentiometers
 Linear Potentiometers Slim Body Series
 Linear Potentiometers Conditioner Circuit
 Magnetostrictive Position Sensors
 Magnetic Linear Incremental Encoders
 Draw Wire Potentiometers/Encoders
 Optic Rotary Absolute Encoders
 Magnetic Rotary Encoders
 Optic Rotary Incremental Encoders

Linear Potentiometer Internal Voltage / Current Conditioner Circuit

Internal electronic circuit
 Measuring range 100 - 1950 mm
 Output 4-20 mA, 0-20 mA, 0-10 V
 20-4 mA, 20-0 mA, 10-0 V
 Very low temperature drift
 Very stable output signal
 Excellent repeatability



Technical specifications

Measurement stroke	100 to 1950 mm
Linearity	±%0,05 (>200 mm), ±%0,1 (130 - 200 mm), ±%0,2 (75 - 130 mm), ±%0,5 (<75 mm)
Repeatability	< 0.01 mm
Resolution	Infinite
Output	4 - 20 mA, 0 - 20 mA or 0 - 10 V
Permissible applied voltage	15 - 30 VDC
Electrical connections	4 pin connector
Displacement speed	< 1,5 m/s
Mechanical life	100 million movement
Case dimensions	33 mm x 33 mm
Case material	Anodized aluminium
Rod diameter	Ø6 mm
Rod material	Stainless steel
Mechanical fixing	Variable brackets
IP degree	IP 40 / IP 53 if mounted upside down
Operating temperature	-20°C ... +80°C
Storage temperature	-30°C ... +90°C

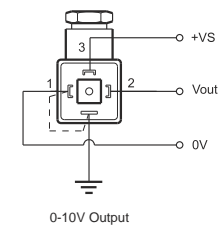
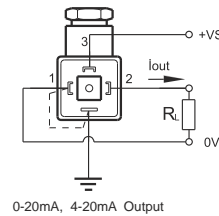
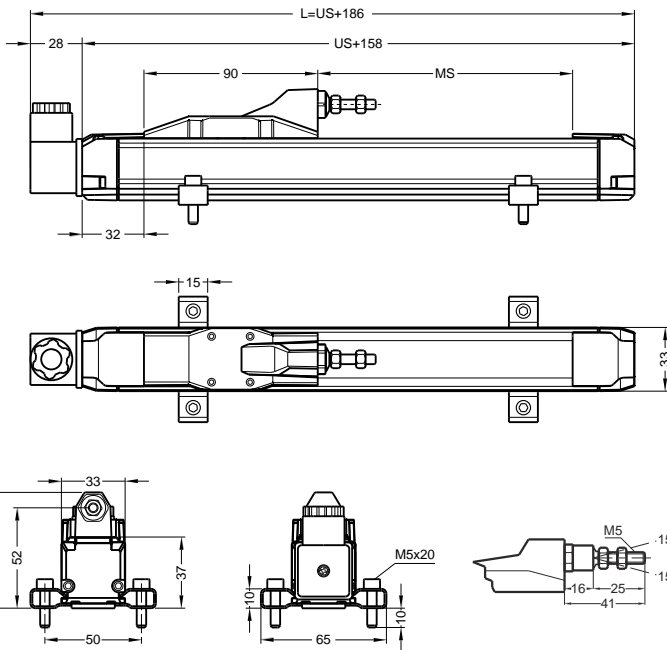

ELPH (mm)	100	125	130	150	175	200	225	250	275	300	325	350	375	400	450	500	550	600	650	700	750	800	850	900	1000	1250	1500	1750	1950
US (Usefull Stroke)	100	125	130	150	175	200	225	250	275	300	325	350	375	400	450	500	550	600	650	700	750	800	850	900	1000	1250	1500	1750	1950
MS (Mechanical Stroke)	104	129	134	154	179	204	229	254	279	304	329	354	379	404	454	504	554	604	654	704	754	804	854	904	1004	1254	1504	1754	1954
L (Total Length)	321	346	351	371	396	421	446	471	496	521	546	571	596	621	671	721	771	821	871	921	971	1021	1071	1121	1221	1471	1721	1921	2121

Model	Measurement stroke (mm)	Linearity (%)	Output	Connector / Cable
(example) ERPH	500	D	V10	C1
ERPH	100 ... 1950 mm	D: ±%0,05 (>200 mm) ±%0,1 (130 - 200 mm) ±%0,2 (75 - 130 mm) ±%0,5 (<75 mm)	I40: 4 - 20 mA I04: 20-4 mA I20: 0 - 20 mA I02: 20-0 mA V10: 0 - 10 V V01: 10-0 V	C1: 4 pin connector

Linear Potentiometer

Internal Voltage / Current Conditioner Circuit

Internal electronic circuit
 Measuring range 50 - 800 mm
 Output 4-20 mA, 0-20 mA, 0-10 V
 20-4 mA, 20-0 mA, 10-0 V
 Very stable output signal
 Very low temperature drift
 Excellent repeatability



Technical specifications

Measurement stroke	50 to 800 mm
Linearity	± %0,05 (>200 mm), ±%0,1 (130 - 200 mm), ±%0,2 (75 - 130 mm), ±%0,5 (<75 mm)
Repeatability	< 0.01 mm
Resolution	Infinite
Output	4-20 mA, 0-20 mA, 0-10 V / 20-4 mA, 20-0 mA, 10-0 V
Permissible applied voltage	15 - 30 VDC
Electrical connections	4 pin connector or 1 m cable
Displacement speed	< 5 m/s
Mechanical life	100 million movement
Case dimensions	Ø38 mm
Case material	Anodized aluminium
Rod diameter	Ø10 mm
Rod material	Stainless steel
Mechanical fixing	Ball joints on the both sides
IP degree	IP 65
Operating temperature	-20°C ... +80°C
Storage temperature	-30°C ... +90°C

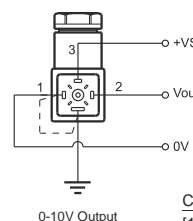
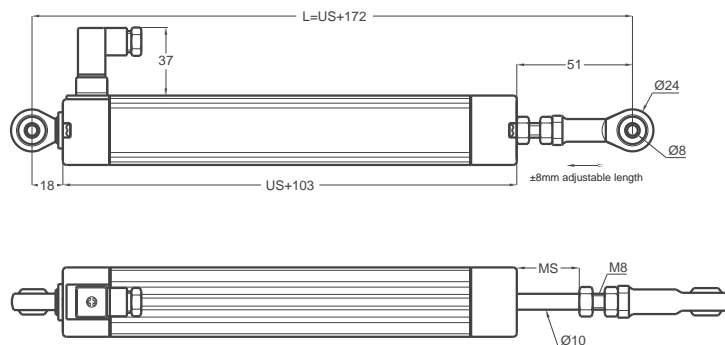

Cable Colors
 [1] Blue : (-)
 [2] Yellow : Vout / Iout
 [3] Brown : (+)
 [4] Black : GND

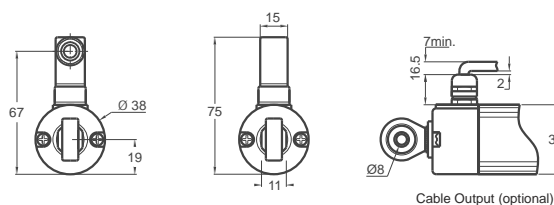
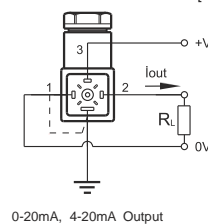

ELPC (mm)	50	75	100	125	130	150	175	200	225	250	275	300	325	350	375	400	450	500	550	600	650	700	750	800
US (Usefull Stroke)	50	75	100	125	130	150	175	200	225	250	275	300	325	350	375	400	450	500	550	600	650	700	750	800
MS (Mechanical Stroke)	55	80	105	130	135	155	180	205	230	255	280	305	330	355	380	405	455	505	555	605	655	705	755	805
L (Total Length)	222	247	272	297	302	322	347	372	397	422	447	472	497	522	547	572	622	672	722	772	822	872	922	972

Model	Measurement stroke (mm)	Linearity (%)	Output	Connector / Cable
(example) ELPC	500	D	V10	C2
ELPC	50 ... 800 mm	D: ±%0,05 (>200 mm) ±%0,1 (130 - 200 mm) ±%0,2 (75 - 130 mm) ±%0,5 (<75 mm)	I40: 4 - 20 mA V10: 0 - 10 V I04: 20-4 mA V01: 10-0 V I20: 0 - 20 mA I02: 20-0 mA	C2 : 4 pin connector 1M5: 1,5 meter cable

Linear Potentiometer Internal Voltage / Current Conditioner Circuit

Internal electronic circuit
 Measuring range 50 - 600 mm
 Output 4-20 mA, 0-20 mA, 0-10 V
 20-4 mA, 20-0 mA, 10-0 V
 Very stable output signal
 Best solution for automation systems
 Excellent repeatability



Technical specifications

Measurement stroke	50 to 600 mm
Linearity	$\pm 0,05$ (>200 mm), $\pm 0,1$ (130 - 200 mm), $\pm 0,2$ (75 - 130 mm), $\pm 0,5$ (<75 mm)
Repeatability	< 0.01 mm
Resolution	Infinite
Output	4-20 mA, 0-20 mA, 0-10 V / 20-4 mA, 20-0 mA, 10-0 V
Permissible applied voltage	15 - 30 VDC
Electrical connections	4 pin connector
Displacement speed	< 5 m/s
Mechanical life	100 million movement
Case dimensions	33 mm x 33 mm
Case material	Anodized aluminium
Rod diameter	$\varnothing 6$ mm
Rod material	Stainless steel
Mechanical fixing	Ball joints on the both sides
IP degree	IP 65
Operating temperature	-20°C ... +80°C
Storage temperature	-30°C ... +90°C

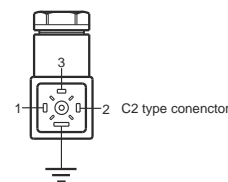
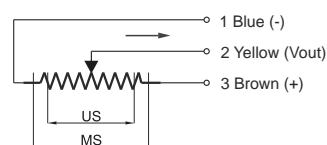
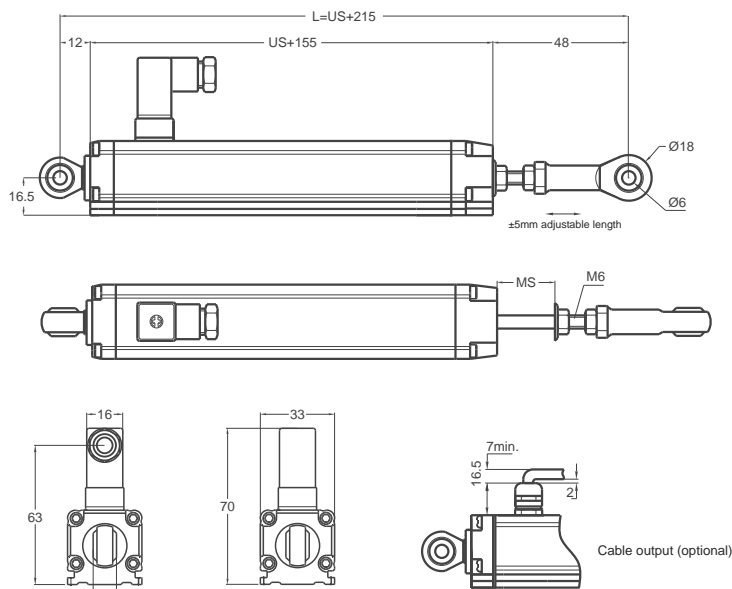

ERTM (mm)	50	75	100	125	130	150	175	200	225	250	275	300	325	350	375	400	450	500	550	600
US (Usefull Stroke)	50	75	100	125	130	150	175	200	225	250	275	300	325	350	375	400	450	500	550	600
MS (Mechanical Stroke)	53	73	103	128	133	153	178	203	228	253	278	303	328	353	373	403	453	503	553	603
L (Total Length)	265	290	315	340	345	365	390	415	440	465	490	515	540	565	590	615	665	715	765	818

Model	Measurement stroke (mm)	Linearity (%)	Output	Connector / Cable
(example) ERTM	500	D	V10	C2
ERTM	50 ... 600 mm	D: $\pm 0,05$ (>200 mm) $\pm 0,1$ (130 - 200 mm) $\pm 0,2$ (75 - 130 mm) $\pm 0,5$ (<75 mm)	I40: 4 - 20 mA V10: 0 - 10 V I04: 20-4 mA V01: 10-0 V I20: 0 - 20 mA I02: 20-0 mA	C2: 4 pin connector

Linear Potentiometer Internal Voltage / Current Conditioner Circuit

Internal electronic circuit
 Measuring range 30 - 1000 mm
 Output 4-20 mA, 0-20 mA, 0-10 V
 20-4 mA, 20-0 mA, 10-0 V
 Very stable output signal
 Best solution for automation systems
 Excellent repeatability



Technical specifications

Measurement stroke	30 to 1000 mm
Linearity	± %0,05 (>200 mm), ±%0,1 (130 - 200 mm), ±%0,2 (75 - 130 mm), ±%0,5 (<75 mm)
Repeatability	< 0.01 mm
Resolution	Infinite
Output	4-20 mA, 0-20 mA, 0-10 V / 20-4 mA, 20-0 mA, 10-0 V
Permissible applied voltage	15 - 30 VDC
Electrical connections	Cable output
Displacement speed	< 5 m/s
Mechanical life	100 million movement
Case dimensions	33 mm x 33 mm
Case material	Anodized aluminium
Rod diameter	Ø6 mm
Rod material	Stainless steel
Mechanical fixing	Variable brackets
IP degree	IP 65
Operating temperature	-20°C ... +80°C
Storage temperature	-30°C ... +90°C

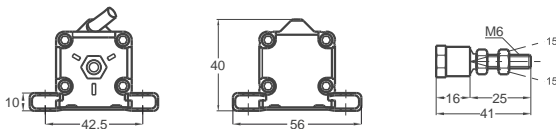
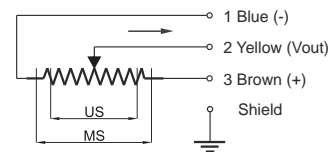
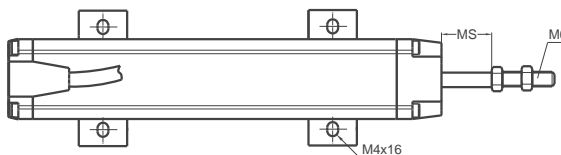
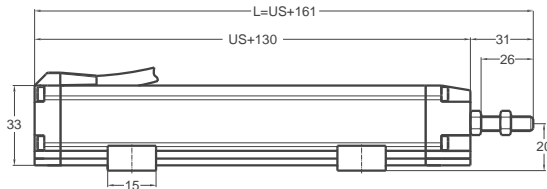

ERTK (mm)	30	50	75	100	125	130	150	175	200	225	250	275	300	325	350	375	400	450	500	550	600	650	700	750	800	850	900	1000
US (Usefull Stroke)	30	50	75	100	125	130	150	175	200	225	250	275	300	325	350	375	400	450	500	550	600	650	700	750	800	850	900	1000
MS (Mechanical Stroke)	33	53	73	103	128	133	153	178	203	228	253	278	303	328	353	373	403	453	503	553	603	653	703	753	803	853	903	1003
L (Total Length)	191	211	236	261	286	291	311	336	361	386	411	436	461	486	511	536	561	611	661	711	761	811	861	911	961	1011	1061	1161

Model	Measurement stroke (mm)	Linearity (%)	Output	Connector / Cable
(example) ERTK	500	D	V10	1M
ERTK	30 ... 1000 mm	D: ±%0,05 (>200 mm) ±%0,1 (130 - 200 mm) ±%0,2 (75 - 130 mm) ±%0,5 (<75 mm)	I40: 4 - 20 mA V10: 0 - 10 V I04: 20-4 mA V01: 10-0 V I20: 0 - 20 mA I02: 20-0 mA	1M : 1 meter cable (standard) 2M5: 2,5 meter cable

Linear Potentiometers
 Linear Potentiometers Slim Body Series
 Linear Potentiometers Conditioner Circuit
 Magnetostrictive Position Sensors
 Magnetic Linear Incremental Encoders
 Draw Wire Potentiometers/Encoders
 Optic Rotary Absolute Encoders
 Magnetic Rotary Encoders
 Optic Rotary Incremental Encoders

Linear Potentiometer BUS Output

Measuring range 30 - 1000 mm
15 bit resolution
CANopen protocol



CANopen Technical specifications

Interface	CAN
Protocol	CANopen, CANbus
Communication profile	CiA301, CiA406 V3.2
Node number	1 up to 127 (fabrika ayarı Node ID: 88)
Green LED	Power on, Can communication active
Red LED	Error, Stop mode
Protection	IP65



PROFIBUS Technical specifications

Interface	PROFIBUS-DP
Protocol	PROFIBUS-DP V0/V1/V2
Line Driver	Galvanic isolated
Node addressing	By switches or software
Baud rate	Max. 12 Mbit/s
Green LED	Power on, PROFIBUS communication active
Red LED	Error, Stop mode
Protection	IP65

EtherCAT Technical specifications

Interface	EtherCAT Ethernet control automation technology
Protocol	EtherCAT 100 Base-Tx, Fast Ethernet
Baud rate	Max. 100 Mbit/s
Green LED	Power on, EtherCAT communication active
Red LED	Error, Stop mode
Protection	IP65

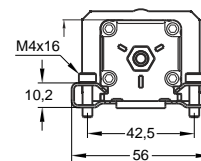
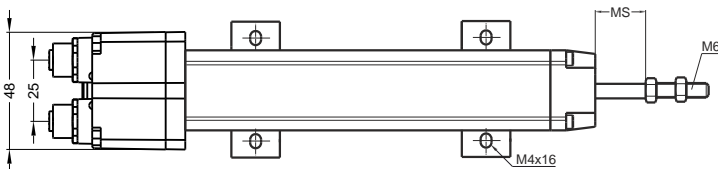
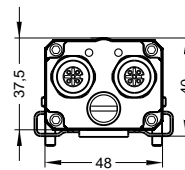
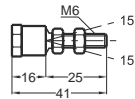
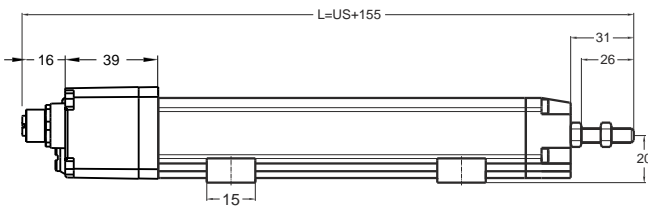

DRTL (mm)	30	50	75	100	125	130	150	175	200	225	250	275	300	325	350	375	400	450	500	550	600	650	700	750	800	850	900	1000
US (Usefull Stroke)	30	50	75	100	125	130	150	175	200	225	250	275	300	325	350	375	400	450	500	550	600	650	700	750	800	850	900	1000
MS ±0,5 (Mechanical Stroke)	33	53	73	103	128	133	153	178	203	228	253	278	303	328	353	373	403	453	503	553	603	653	703	753	803	853	903	1003
L (Total Length)	185	205	230	255	280	285	305	330	355	380	405	430	455	480	505	530	555	605	655	705	755	805	855	905	955	1005	1055	1155

Magnetostrictive Position Sensor

Measuring range 100 - 3000 mm
 16 bit resolution
 Output 0...10 V, 0...20 mA, 4...20 mA
 10...0 V, 20...0 mA, 20-4 mA
 24 VDC power supply



Technical specifications

Measurement stroke	100 to 3000 mm
Resolution	16 bit DAC output
Repeatability	±0,005% (full scale)
Output	0-10 V, 4-20 mA, 0-20 mA / 10-0 V, 20-4 mA, 20-0 mA
Power supply	24 VDC ±10%
Displacement speed	< 10 m/s
Sampling rate	up to 2 kHz (depending on stroke length)
Max. okuma mesafesi	3 mm
Max. consumption	50 mA - 90 mA (depending on stroke length)
Max. output noise	< 5 mVpp
Max. output value	10.5 V
Linearity	±0,02% full scale (min. 100 µm)
Update time	0,5 ms up to 1000 m / 0,8 ms up to 2000 m
Reverse polarity protection	Up to -30 VDC
Overvoltage protection	Up to 40 VDC
IP degree	IP 65

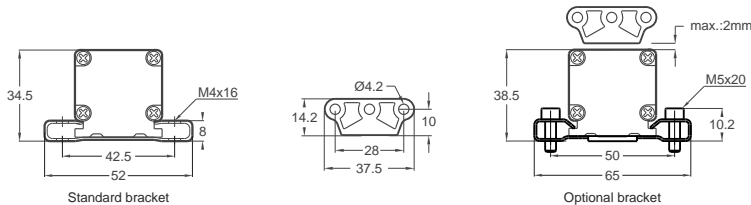
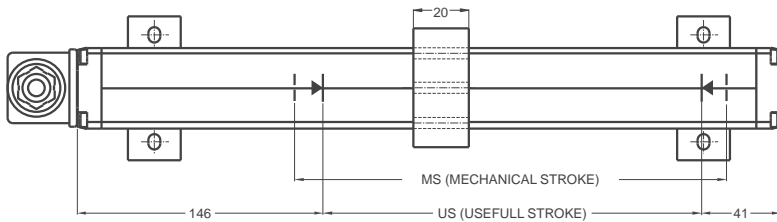
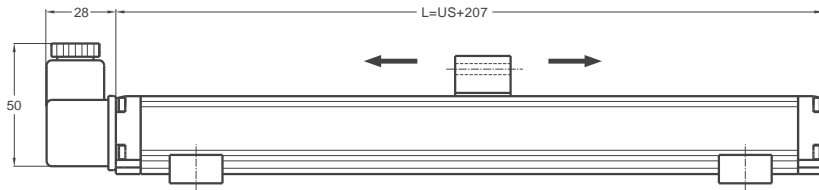

MSS (mm)	100	150	200	250	300	350	400	450	500	550	600	650	700	750	800	850	900	1000	1100	1200	1300	1400	1500	1750	2000	2250	2500	3000
US (Usefull Stroke)	120	170	220	270	320	370	420	470	520	570	620	670	720	770	820	870	920	1020	1120	1220	1320	1420	1520	1770	2020	2270	2520	3020
MS (Mechanical Stroke)	160	210	260	310	360	410	460	510	560	610	660	710	760	810	860	910	960	1060	1160	1260	1360	1460	1560	1810	2060	2310	2560	3060
L (Total Length)	307	357	407	457	507	557	607	657	707	757	807	857	907	957	1007	1057	1107	1207	1307	1407	1507	1607	1707	1957	2207	2457	2707	3207

Model	Measurement stroke	Resolution	Output	Connector / Cable
(example) MSS	300	A	V10	C1
MSS	100 ... 3000 mm	A: 16 bit	V10: 0 - 10 V V01: 10 - 0 V I40 : 4 - 20 mA I20 : 0 - 20 mA I04 : 20 - 4 mA V11: 0 - 10 V / 10 - 0 V I41 : 4 - 20 mA / 20 - 4 mA I21 : 0 - 20 mA / 20 - 0 mA	C1: 4 pin connector

Linear Potentiometers
 Linear Potentiometers Slim Body Series
 Linear Potentiometers Conditioner Circuit
 Magnetostrictive Position Sensors
 Magnetic Linear Incremental Encoders
 Draw Wire Potentiometers/Encoders
 Optic Rotary Absolute Encoders
 Magnetic Rotary Encoders
 Optic Rotary Incremental Encoders

Magnetostrictive Position Sensor

Measuring range 100 - 3000 mm
 16 bit resolution
 Output 0...10 V, 0...20 mA, 4...20 mA
 10...0 V, 20...0 mA, 20-4 mA
 24 VDC power supply



Technical specifications

Measurement stroke	100 to 3000 mm
Resolution	16 bit DAC output
Repeatability	±0,005% (full scale)
Output	0-10 V, 4-20 mA, 0-20 mA / 10-0 V, 20-4 mA, 20-0 mA
Power supply	24 VDC ±10%
Displacement speed	< 10 m/s
Sampling rate	up to 2 kHz (depending on stroke length)
Max. consumption	50 mA - 90 mA (depending on stroke length)
Max. output noise	< 5 mVpp
Max. output value	10.5 V
Linearity	±0,02% full scale (min. 100 µm)
Update time	0,5 ms up to 1000 m / 0,8 ms up to 2000 m
Reverse polarity protection	Up to -30 VDC
Overvoltage protection	Up to 40 VDC
IP protection	IP 65

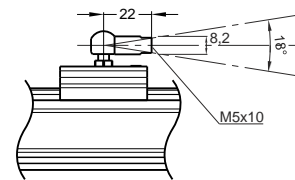
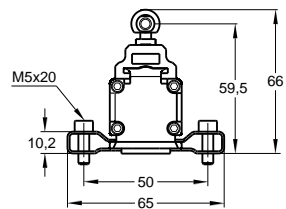
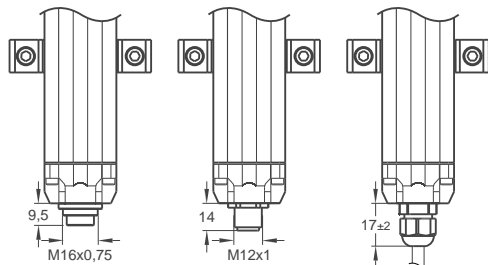
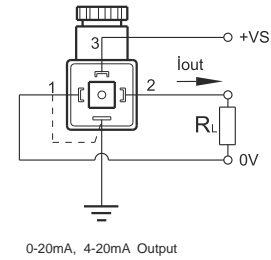
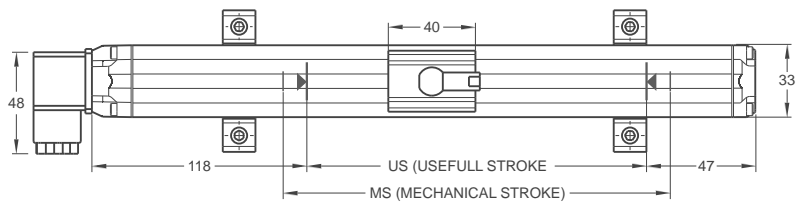
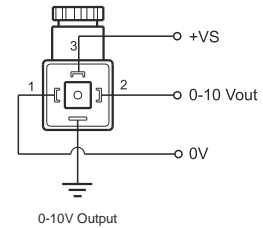
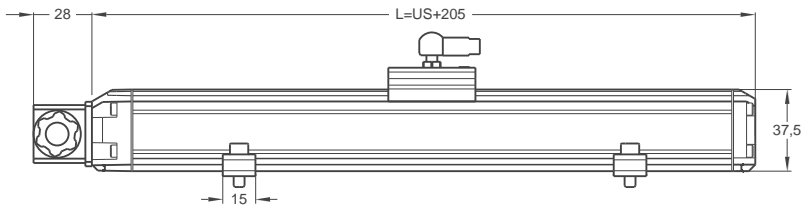

MSW (mm)	100	150	200	250	300	350	400	450	500	550	600	650	700	750	800	850	900	1000	1100	1200	1300	1400	1500	1750	2000	2250	2500	3000
US (Usefull Stroke)	140	190	240	290	340	390	440	490	540	590	640	690	740	790	840	890	940	1040	1140	1240	1340	1440	1540	1790	2040	2290	2540	3040
MS (Mechanical Stroke)	160	210	280	310	360	410	460	510	560	610	660	710	760	810	860	910	960	1060	1160	1260	1360	1460	1560	1810	2060	2310	2560	3060
L (Total Length)	305	355	405	455	505	555	605	655	705	755	805	855	905	955	1005	1055	1105	1205	1305	1405	1505	1605	1705	1955	2205	2455	2705	3205

Model	Measurement stroke	Resolution	Output	Connector / Cable
(example) MSW	300	A	V10	C1
MSW	100 ... 3000 mm	A: 16 bit	V10: 0 - 10 V V01: 10 - 0 V I40 : 4 - 20 mA I20 : 0 - 20 mA I04 : 20 - 4 mA V11: 0 - 10 V / 10 - 0 V I41 : 4 - 20 mA / 20 - 4 mA I21 : 0 - 20 mA / 20 - 0 mA	C1: 4 pin connector

Magnetostrictive Position Sensor

Measuring range 100 - 3000 mm
 16 bit resolution
 Output 0...10 V, 0...20 mA, 4...20 mA
 10...0 V, 20...0 mA, 20-4 mA
 24 VDC power supply



Technical specifications

Measurement stroke	100 to 3000 mm
Resolution	16 bit DAC output
Repeatability	±0,005% (full scale)
Output	0-10 V, 4-20 mA, 0-20 mA / 10-0 V, 20-4 mA, 20-0 mA
Power supply	24 VDC ±10%
Displacement speed	< 10 m/s
Sampling rate	up to 2 kHz (depending on stroke length)
Max. consumption	50 mA - 90 mA (depending on stroke length)
Max. output noise	< 5 mVpp
Max. output value	10.5 V
Linearity	±0,02% full scale (min. 100 µm)
Update time	0,5 ms up to 1000 m / 0,8 ms up to 2000 m
Reverse polarity protection	Up to -30 VDC
Overvoltage protection	Up to 40 VDC
IP protection	IP 65

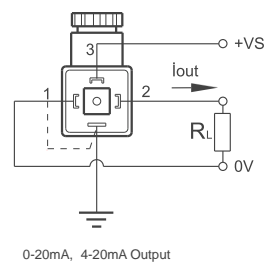
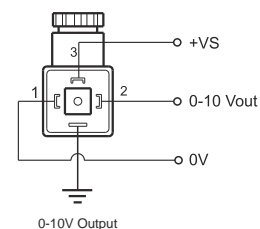
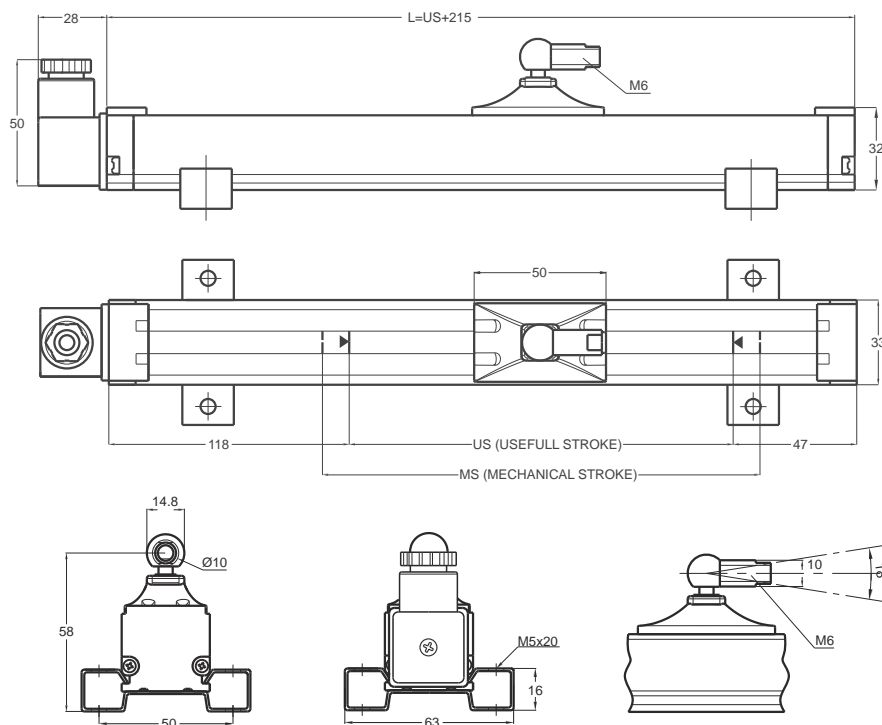

MSH (mm)	100	150	200	250	300	350	400	450	500	550	600	650	700	750	800	850	900	1000	1100	1200	1300	1400	1500	1750	2000	2250	2500	3000
US (Usefull Stroke)	150	200	250	300	350	400	450	500	550	600	650	700	750	800	850	900	950	1050	1150	1250	1350	1450	1550	1800	2050	2300	2550	3050
MS (Mechanical Stroke)	170	220	270	320	370	420	470	520	570	620	670	720	770	820	870	920	970	1070	1170	1270	1370	1470	1570	1820	2070	2320	2570	3070
L (Total Length)	315	365	415	465	515	565	615	665	715	765	815	865	915	965	1015	1065	1115	1215	1315	1415	1515	1615	1715	1965	2215	2465	2715	3215

Model	Measurment stroke	Resolution	Output	Connector / Cable
(example) MSH	300	A	V10	C1
MSH	100 ... 3000 mm	A: 16 bit	V10: 0 - 10 V V01: 10 - 0 V I40 : 4 - 20 mA I20 : 0 - 20 mA I04 : 20 - 4 mA V11: 0 - 10 V / 10 - 0 V I41 : 4 - 20 mA / 20 - 4 mA I21 : 0 - 20 mA / 20 - 0 mA	C1: 4 pin connector

Linear Potentiometers
 Linear Potentiometers Slim Body Series
 Linear Potentiometers Conditioner Circuit
 Magnetostrictive Position Sensors
 Magnetic Linear Incremental Encoders
 Draw Wire Potentiometers/Encoders
 Optic Rotary Absolute Encoders
 Magnetic Rotary Encoders
 Optic Rotary Incremental Encoders

Magnetostrictive Position Sensor

Measuring range 100 - 3000 mm
 16 bit resolution
 Output 0...10 V, 0...20 mA, 4...20 mA
 10...0 V, 20...0 mA, 20-4 mA
 24 VDC power supply



Technical specifications

Measurement stroke	100 to 3000 mm
Resolution	16 bit DAC output
Repeatability	±0,005% (full scale)
Output	0-10 V, 4-20 mA, 0-20 mA / 10-0 V, 20-4 mA, 20-0 mA
Power supply	24 VDC ±10%
Displacement speed	< 10 m/s
Sampling rate	up to 2 kHz (depending on stroke length)
Max. consumption	50 mA - 90 mA (depending on stroke length)
Max. output noise	< 5 mVpp
Max. output value	10.5 V
Linearity	±0,02% full scale (min. 100 µm)
Update time	0,5 ms up to 1000 m / 0,8 ms up to 2000 m
Reverse polarity protection	Up to -30 VDC
Overvoltage protection	Up to 40 VDC
Pressure rating	< 500 bar
Mounting	M18 x 1.5
Housing material	Profile: Anodized aluminium, Tube: Stainless steel, Caps: Stainless steel
IP protection	IP 65

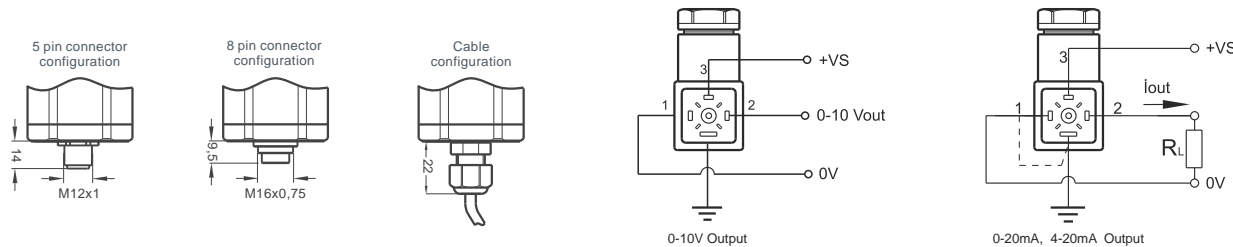
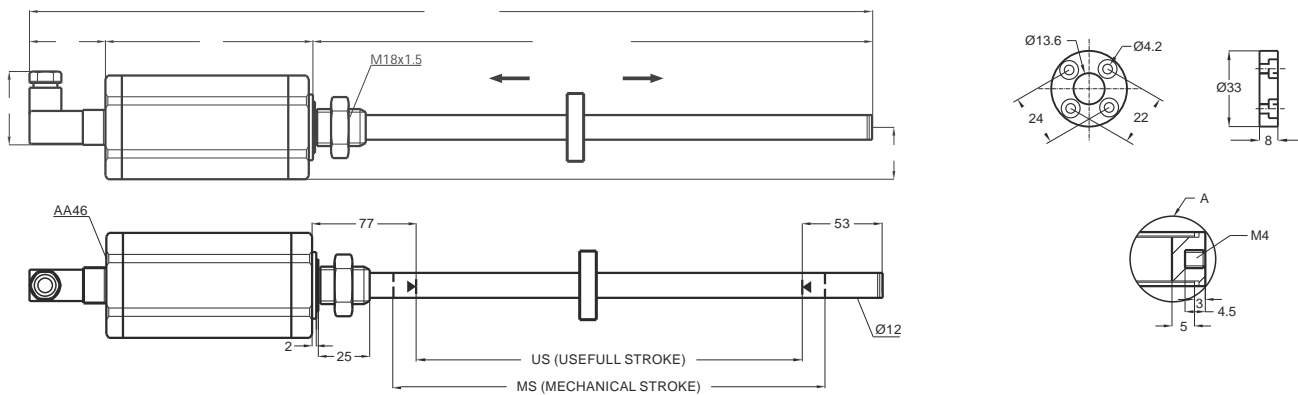

MST (mm)	100	150	200	250	300	350	400	450	500	550	600	650	700	750	800	850	900	1000	1100	1200	1300	1400	1500	1750	2000	2250	2500	3000
US (Usefull Stroke)	108	158	208	258	308	358	408	458	508	558	608	658	708	758	808	858	908	1008	1108	1208	1308	1408	1508	1758	2008	2258	2508	3008
MS (Mechanical Stroke)	128	178	228	278	328	378	428	478	528	578	628	678	728	778	828	878	928	1028	1128	1228	1328	1428	1528	1778	2028	2278	2528	3028
LT (Total Length)	238	288	338	388	438	488	538	588	638	688	738	788	838	888	938	988	1038	1138	1238	1338	1438	1538	1638	1888	2138	2388	2638	3138

Model	Measurement stroke	Resolution	Output	Connector / Cable
(example) MST	900	A	V10	C2
MST	100 ... 3000 mm	A: 16 bit	V10: 0 - 10 V V01: 10 - 0 V I40 : 4 - 20 mA I20 : 0 - 20 mA I04 : 20 - 4 mA V11: 0 - 10 V / 10 - 0 V I41 : 4 - 20 mA / 20 - 4 mA I21 : 0 - 20 mA / 20 - 0 mA	C2 : 4 pin connector 1M : 1 meter cable 2M5: 2,5 meter cable

Magnetostrictive Position Sensor BUS Output

Measuring range 100 - 3000 mm
15 bit resolution
CANbus, CANopen



CANopen Technical specifications

Interface	CAN
Protocol	CANopen, CANbus
Communication profile	CiA301, CiA406 V3.2
Node number	1 up to 127 (default Node ID: 88)
Green LED	Power on, Can communication active
Red LED	Error, Stop mode
Protection	IP65



Technical specifications

Interface	PROFIBUS-DP
Protocol	PROFIBUS-DP V0/V1/V2
Line Driver	Galvanic isolated
Node addressing	By switches or software
Baud rate	Max. 12 Mbit/s
Green LED	Power on, PROFIBUS communication active
Red LED	Error, Stop mode
Protection	IP65



Technical specifications

Interface	EtherCAT Ethernet control automation technology
Protocol	EtherCAT 100 Base-Tx, Fast Ethernet
Baud rate	Max. 100 Mbit/s
Green LED	Power on, EtherCAT communication active
Red LED	Error, Stop mode
Protection	IP65

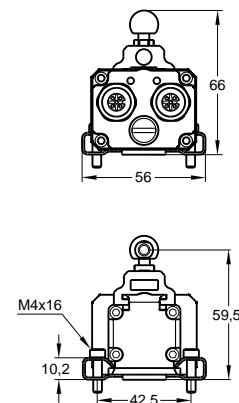
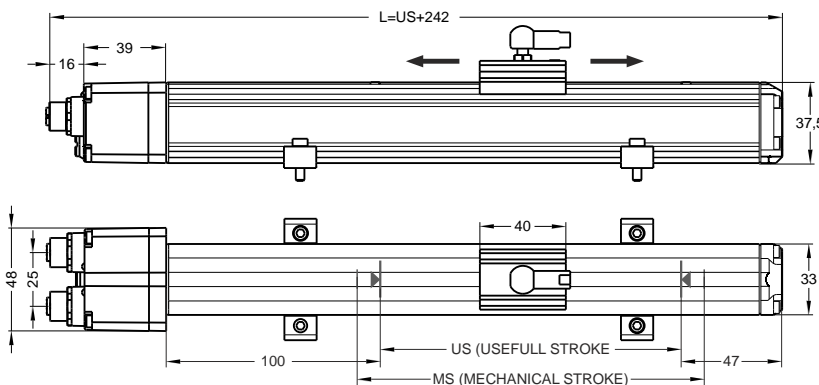

DMSW (mm)	100	150	200	250	300	350	400	450	500	550	600	650	700	750	800	850	900	1000	1100	1200	1300	1400	1500	1600	1700	1800	1900	2000
US (Usefull Stroke)	140	190	240	290	340	390	440	490	540	590	640	690	740	790	840	890	940	1040	1140	1240	1340	1440	1540	1640	1740	1840	1940	2040
MS (Mechanical Stroke)	160	210	280	310	360	410	460	510	560	610	660	710	760	810	860	910	960	1060	1160	1260	1360	1460	1560	1660	1760	1860	1960	2060
L (Total Length)	342	392	442	492	542	592	642	692	742	792	842	892	942	992	1042	1092	1142	1242	1342	1442	1542	1642	1742	1842	1942	2042	2142	2242

Model	Measurement stroke	Protocol	Protocol	Termination	Supply	Connector / Cable
(example) DMSW	200	COB	5BR	1S0	V4	2C5
DMSW	100 ... 3000 mm	COB: CANopen CAB: CANbus PFB: ProfiBUS ETN: EtherCAT SSI : SSI	0BR : 10 Kbit/s 1BR : 20 Kbit/s 2BR : 50 Kbit/s 3BR : 100 Kbit/s 4BR : 125 Kbit/s 5BR : 250 Kbit/s 6BR : 500 Kbit/s 7BR : 800 Kbit/s 8BR : 1 Mbit/s	120R Bus termination resistor 1S0: Switch off 1S1: Switch on	V4: 24 VDC	1C5: 5 pin, 1 connector (M12x1) 2C5: 5 pin, 2 connector (M12x1)

Linear Potentiometers
Linear Potentiometers Slim Body Series
Linear Potentiometers Conditioner Circuit
Magnetostrictive Position Sensors
Magnetic Linear Incremental Encoders
Draw Wire Potentiometers/Encoders
Optic Rotary Absolute Encoders
Magnetic Rotary Encoders
Optic Rotary Incremental Encoders

Magnetostrictive Position Sensor BUS Output



Measuring range 100 - 3000 mm
15 bit resolution
CANbus, CANopen

CANopen Technical specifications

Interface	CAN
Protocol	CANopen, CANbus
Communication profile	CiA301, CiA406 V3.2
Node number	1 up to 127 (default Node ID: 88)
Green LED	Power on, Can communication active
Red LED	Error, Stop mode
Protection	IP65



PROFIBUS Technical specifications

Interface	PROFIBUS-DP
Protocol	PROFIBUS-DP V0/V1/V2
Line Driver	Galvanic isolated
Node addressing	By switches or software
Baud rate	Max. 12 Mbit/s
Green LED	Power on, PROFIBUS communication active
Red LED	Error, Stop mode
Protection	IP65



EtherCAT Technical specifications

Interface	EtherCAT Ethernet control automation technology
Protocol	EtherCAT 100 Base-Tx, Fast Ethernet
Baud rate	Max. 100 Mbit/s
Green LED	Power on, EtherCAT communication active
Red LED	Error, Stop mode
Protection	IP65

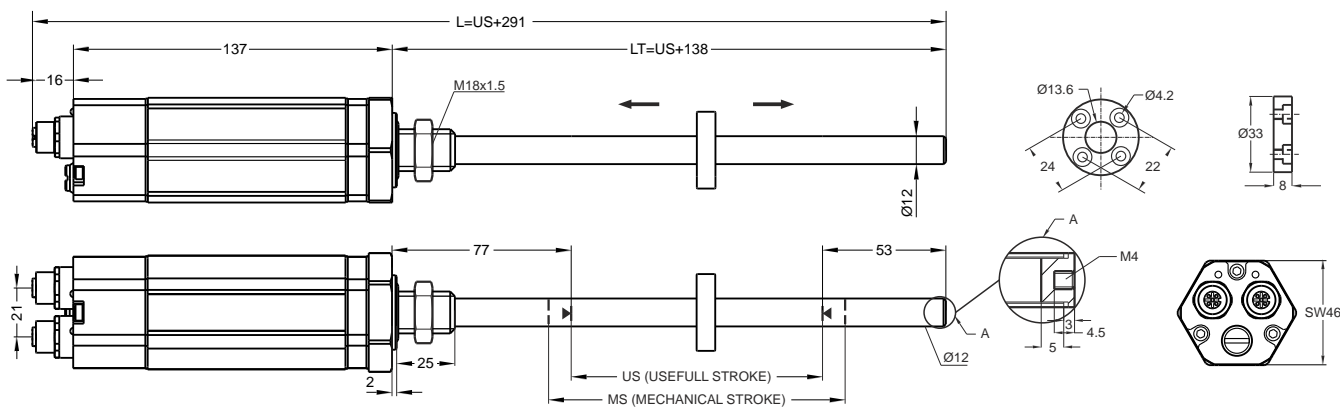

DMST (mm)	100	150	200	250	300	350	400	450	500	550	600	650	700	750	800	850	900	1000	1100	1200	1300	1400	1500	1600	1700	1800	1900	2000
US (Usefull Stroke)	108	158	208	258	308	358	408	458	508	558	608	658	708	758	808	858	908	1008	1108	1208	1308	1408	1508	1608	1708	1808	1908	2008
MS (Mechanical Stroke)	128	178	228	278	328	378	428	478	528	578	628	678	728	778	828	878	928	1028	1128	1228	1328	1428	1528	1628	1728	1828	1928	2028
LT	238	288	338	388	438	488	538	588	638	688	738	788	838	888	938	988	1038	1138	1238	1338	1438	1538	1638	1738	1838	1938	2038	2138
L (Total Length)	391	441	491	541	591	641	691	741	791	841	891	941	991	1041	1091	1141	1191	1291	1391	1491	1591	1691	1791	1891	1991	2091	2191	2291

Model	Measurement stroke	Protocol	Protocol	Termination	Supply	Connector / Cable
(example) DMSW	200	COB	5BR	1S0	V4	2C5
DMSW	100 ... 3000 mm	COB: CANopen CAB: CANbus PFB: Profibus ETN: EtherCAT SSI: SSI	0BR : 10 Kbit/s 1BR : 20 Kbit/s 2BR : 50 Kbit/s 3BR : 100 Kbit/s 4BR : 125 Kbit/s 5BR : 250 Kbit/s 6BR : 500 Kbit/s 7BR : 800 Kbit/s 8BR : 1 Mbit/s	120R Bus termination resistor 1S0: Switch off 1S1: Switch on	V4: 24 VDC	1C5: 5 pin, 1 connector (M12x1) 2C5: 5 pin, 2 connector (M12x1)

Magnetic Linear Incremental Encoder

2,5 / 5 / 10 / 12,5 / 20 / 25 μm resolution as standard

Other options on request

Magnetic contactless measurement

Push-Pull, TTL Linedriver or HTL Linedriver output options

Single reference standard or continuous reference optional

Weak magnetic field and power on LEDs

IP 66 protection



Technical specifications

Pole pitch	2 mm, 5 mm
Gap between reader head and tape (max.)	2.5 mm
Resolution	2,5 / 5 / 10 / 12,5 / 20 / 25 μm resolution (4x mode)
Type of measurement	Magnetic incremental non-contact
Accuracy	$\pm 15 \mu\text{m}$
Output type	Push-Pull, TTL Linedriver, HTL Linedriver
Supply voltage	8-24 VDC (standard), 5 VDC (optional)
Electrical connections	2,5 m cable (standard), 1 m cable with DB9 connector (optional)
Case material	Anodized aluminium
Max. speed	3 m/s with LED indicator (standard) 15 m/s without LED indicator (optional)
IP degree	IP 66
Operating temperature	-20°C ... +80°C
Storage temperature	-30°C ... +90°C

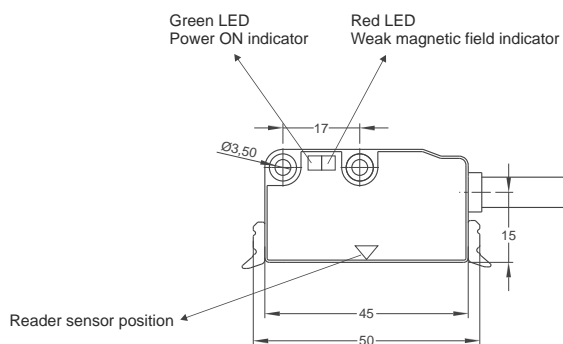

Linedriver Cable Output

Ch A : Black
Ch A inv. : Yellow
Ch B : White
Ch B inv. : Green
Ch Z : Orange
Ch Z inv. : Red
+V : Brown
0V : Blue
GND : Shield

Push-Pull Cable Output

Ch A : Black
Ch B : White
Ch Z : Orange
+V : Brown
0V : Blue
GND : Shield

Model	Resolution	Output type	Pole pitch	Output channels	Supply voltage	Connector / Cable
(example) MLI	T20	LTP	5	B	V2	1M
MLI	T10 : 2,5 μm T20 : 5 μm T40 : 10 μm T50 : 12,5 μm T80 : 20 μm T100: 25 μm	LTP : Push-Pull TT : TTL Linedriver HLD: High Linedriver	2: 2mm pole pitch 5: 5mm pole pitch	B : A, B 5Z: A, B, Z (Continues reference)	V1: 5V DC V2: 8-24V DC	1M : 1 meter cable (standard) 2M5: 2,5 meter cable 9C : 0,5 meter cable with 9 pin connector

MT2, MT5 MP1, MP2

Magnetic Tape and Aluminium Profile

2 or 5 mm pole pitches
 ± 40µm, accuracy
 Self adhesive magnetic tapes
 Industrial standart dimensions 10 mm x 1,5 mm
 IP 67 protection

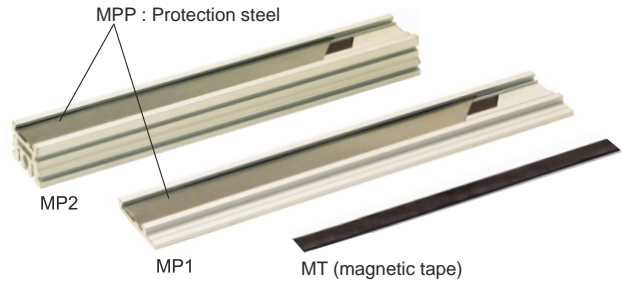

Magnetic tape technical specifications

Pole pitch	2 mm, 5 mm
Accuracy	± 40 µm
Dimensions	10 mm x 1,5 mm
Max. stroke	Up to 50 m single piece
Cover strip	Stainless steel
Mechanical fixing	Self adhesive
IP degree	IP 67
Operating temperature	-20°C ... +80°C
Storage temperature	-30°C ... +90°C

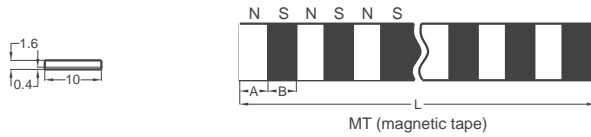

Pole pitches	A (mm)	B (mm)	L
MT 2	2	2	Up to 50m single piece. Longer stroke on request
MT 5	5	5	

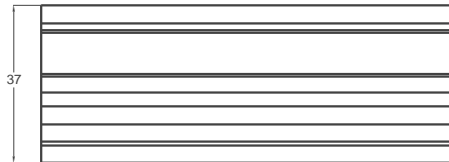
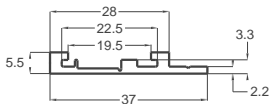

MP1 Aluminium profile

Model	Length
(example) MTP	2M
MTP (protection steel)	2M: 2 meter (Up to 50 meters)

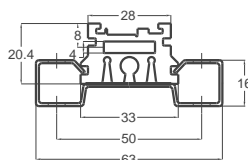

MP2 Aluminium profile

Model	Length
(example) MPP	2M
MPP (protection steel)	2M: 2 meter (Up to 50 meters)

Model	Length
(example) MP1	2M
MP1 MP2	2M: 2 meter (Up to 3 meters)

Model	Pole pitches	Accuracy	Length (meter)
(example) MT	5	A40	5M
MT (magnetic tape)	2: 2 mm 5: 5 mm	A10: ± 10 µm A20: ± 20 µm A40: ± 40 µm	5M: 5 meter (Up to 50 meters)

Magnetic Linear Incremental Encoder For Press Brake / Advanced Design

- 5 µm resolution (4x mode) as standard.
- Other resolutions optional
- Measuring range 150 - 2000 mm
- Adjustable reference
- LED status indicators
- Full symmetrical
- Protective steel cover for measurement tape
- High precision bearings for smooth movement
- ± 15 µm accuracy

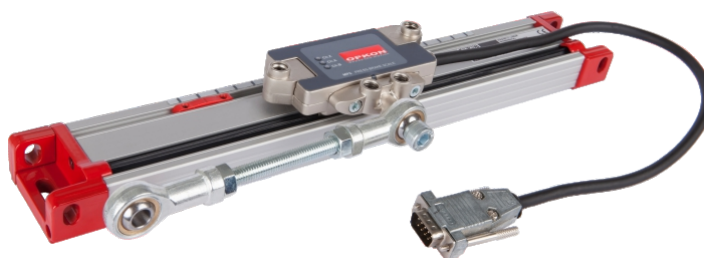

Technical Specifications

Type of measurement	Magnetic incremental non-contact
Measurement stroke	150 to 2000 mm
Resolution	Standard: 5 µm (4x mode), Optional: 2,5 / 5 / 10 / 12,5 / 20 / 25 µm (4x mode)
Repeatability	± 5 µm
Accuracy	± 15 µm
Output channels	A, \bar{A} , B, \bar{B} , Z, \bar{Z}
Output type	TTL Linedriver (standard), Push-Pull / HLD Linedriver (optional)
Supply voltage	5 VDC (standard), 8 - 24 VDC (optional)
Power consumption (without load)	< 40 mA (24 VDC)
Electrical connections	DB9 connector with 1 m cable
Max. speed	< 3 m/s
Case material	Anodized aluminium
IP degree	IP 65
Operating temperature	-20°C ... +80°C
Storage temperature	-30°C ... +90°C

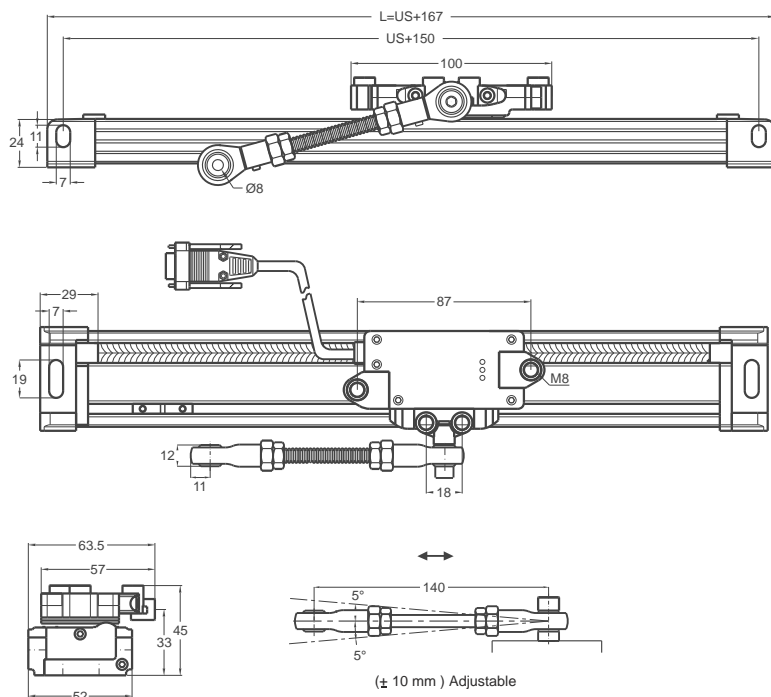

PIN CONFIGURATION

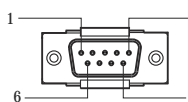

Cable output

- V+ : Brown
- 0V : Blue
- A : Black
- B : White
- Z : Orange
- A inv. : Yellow
- B inv. : Green
- Z inv. : Red
- GND : Earth

9G Type Electrical Connection

- Pin 1 : Ch A
- Pin 2 : Ch A inv.
- Pin 3 : Ch Z
- Pin 4 : Ch B
- Pin 5 : Ch B inv.
- Pin 6 : Ch Z inv.
- Pin 7 : +V
- Pin 8 : GND
- Pin 9 : Earth

9H Type Electrical Connection

- Pin 1 : Ch Z
- Pin 2 : Ch B
- Pin 3 : Ch A
- Pin 4 : NC
- Pin 5 : GND
- Pin 6 : Ch Z inv.
- Pin 7 : Ch B inv.
- Pin 8 : Ch A inv.
- Pin 9 : +V

MPS (mm)	150	170	220	270	320	370	420	470	520	570	620	670	720	820	870	920	1000	1100	1200	1300	1400	1500	1750	2000
US (Usefull Stroke)	150	170	220	270	320	370	420	470	520	570	620	670	720	820	870	920	1000	1100	1200	1300	1400	1500	1750	2000
MS (Mechanical Stroke)	178.5	198.5	248.5	298.5	348.5	398.5	448.5	498.5	548.5	598.5	648.5	698.5	748.5	848.5	898.5	951.5	1028.5	1128.5	1228.5	1328.5	1428.5	1528.5	1778.5	2028.5
L (Total Length)	317	337	387	437	487	537	587	637	687	737	787	837	887	987	1037	1087	1167	1267	1367	1467	1567	1667	1917	2167

Model	Pole pitch	Measurement Stroke	Resolution	Output Type	Reference Output	Supply Voltage	Connector / Cable
(example) MPS	B5	270	T20	LD	4Z	V1	9G
MPS	B2: 2mm pole pitch B5: 5mm pole pitch	150 ... 2000 mm	T10 : 2,5 µm T20 : 5 µm T40 : 10 µm T50 : 12,5µm T80 : 20 µm T100: 25 µm	LD : TTL Linedriver LTP : Push-Pull HLD: HTL Linedriver	4Z: Adjustable reference 5Z: Continuous reference	V1: 5 VDC V2: 8-24 VDC	9G: G type electrical connections with 1 meter cable 9H: H type electrical connections with 1 meter cable

Linear Potentiometers
 Linear Potentiometers Slim Body Series
 Linear Potentiometers Conditioner Circuit
 Magnetostrictive Position Sensors
 Magnetic Linear Incremental Encoders
 Draw Wire Potentiometers/Encoders
 Optic Rotary Absolute Encoders
 Magnetic Rotary Encoders
 Optic Rotary Incremental Encoders

Magnetic Linear Incremental Encoder Special for Roll-Bending Machinery

2,5 / 5 / 10 / 12,5 / 20 / 25 µm resolution (4x mode)
 Measuring range 50 - 800 mm
 Magnetic contactless measurement
 TTL Linedriver, HTL Linedriver outputs optional
 IP 65 protection



Technical specifications

Type of measurement	Magnetic incremental non-contact
Measurement stroke	50 to 800 mm
Resolution	2,5 / 5 / 10 / 12,5 / 20 / 25 µm resolution (4x mode)
Accuracy	± 40 µm
Output channels	A,B, / A,Ā, B,Ā
Output type	Push-Pull, TTL Linedriver, HTL Linedriver
Supply voltage	8 - 24 VDC or 5 VDC
Power consumption (without load)	< 40 mA (24 VDC)
Electrical connections	4 pin connector (standard), 1 m cable (optional)
Max. speed	< 3m/s
Case material	Anodized aluminium
Mechanical fixing	Ball joints on the both sides
IP degree	IP 65
Operating temperature	-20°C ... +80°C
Storage temperature	-30°C ... +90°C

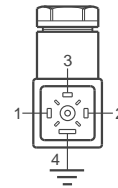
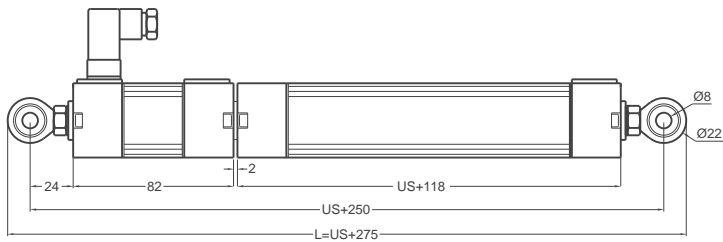

Connector type C2

Linedriver Cable Output

- Ch A : Black
- Ch A inv. : Yellow
- Ch B : White
- Ch B inv. : Green
- +V : Brown
- 0V : Blue
- GND : Shield

Push-Pull Cable Output

- Ch A : Black
- Ch B : White
- +V : Brown
- 0V : Blue
- GND : Shield

Connector Output

- [1] Ch B
- [2] Ch A
- [3] +V
- [4] 0V

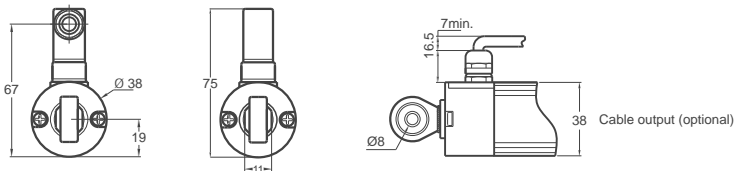
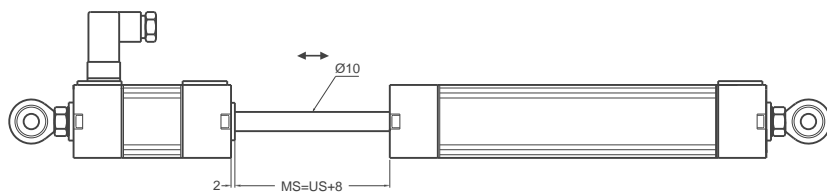

MLC (mm)	50	100	125	150	175	200	225	250	275	300	350	400	450	500	550	600	700	800
US (Usefull Stroke)	50	100	125	150	175	200	225	250	275	300	350	400	450	500	550	600	700	800
MS (Mechanical Stroke)	58	108	133	158	183	208	233	258	283	308	358	408	458	508	558	608	708	808
L (Total Length)	325	375	400	425	450	475	500	525	550	575	625	675	725	775	825	875	975	1075

Model	Measurement stroke	Resolution	Output type	Pole pitch	Output channels	Supply voltage	Connector / Cable
(example) MLC	250	T20 (4x mode)	LTP	B5	B	V2	C2
MLC	50 ... 800 mm	T10 : 2,5 µm T20 : 5 µm T50 : 12,5 µm T80 : 20 µm T100: 25 µm	LTP: Push-Pull LD : Linedriver HTL: HTL Linedriver	B5: 5 mm pole pitch	B: A,B	V1: 5 VDC V2: 8 - 24 VDC	C2 : 4 pin connector 1M : 1 meter cable 2M5: 2,5 meter cable

Magnetic Linear Incremental Encoder

- 2,5 / 5 / 10 / 12,5 / 20 / 25 µm resolution (4x mode)
- Magnetic contactless measurement
- Can be extended up to 50 meter with special fixing parts
- Can be used with multiple reader heads
- Excellent solution for outdoor applications and stone machinery
- IP 66 protection
- TTL Linedriver, HTL Linedriver or Push-Pull outputs

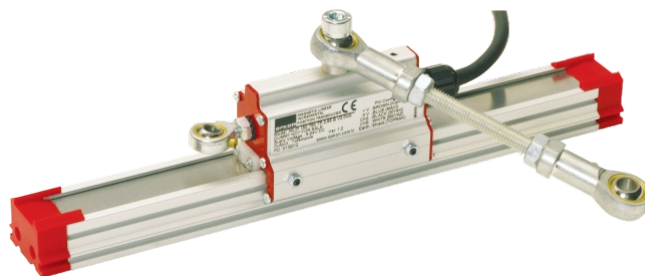

Technical specifications

Type of measurement	Magnetic incremental contactless
Measurement stroke	50 to 5000 mm (can be extend up to 50 meters)
Resolution	2,5 / 5 / 10 / 12,5 / 20 / 25 µm (4x mode)
Accuracy	± 40 µm
Output channels	A,B,Z, / A,Ā, B,Ā, Z,Ā
Output type	Push-Pull, TTL Linedriver, HTL Linedriver
Supply voltage	5 VDC or 8 - 24 VDC
Reference position	Optional
Power consumption (without load)	< 40 mA (24 VDC)
Electrical connections	2.5 m cable standard, DB9 connector with 1 m cable
Case material	Anodized aluminium
IP degree	IP 66
Operating temperature	-20°C ... +80°C
Storage temperature	-30°C ... +90°C

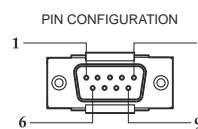
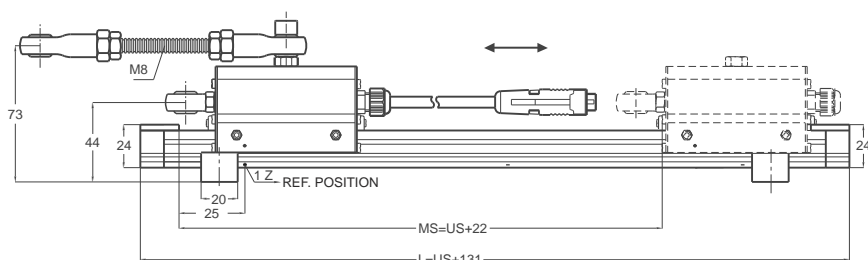

- Cable output**
- V+ : Brown
 - 0V : Blue
 - A : Black
 - B : White
 - Z : Orange
 - A inv. : Yellow
 - B inv. : Green
 - Z inv. : Red
 - GND : Earth

9G Type Electrical Connections

- Pin 1 : Ch A
- Pin 2 : Ch A inv.
- Pin 3 : Ch Z
- Pin 4 : Ch B
- Pin 5 : Ch B inv.
- Pin 6 : Ch Z inv.
- Pin 7 : +V
- Pin 8 : GND
- Pin 9 : Earth

9H Type Electrical Connections

- Pin 1 : Ch Z
- Pin 2 : Ch B
- Pin 3 : Ch A
- Pin 4 : NC
- Pin 5 : GND
- Pin 6 : Ch Z inv.
- Pin 7 : Ch B inv.
- Pin 8 : Ch A inv.
- Pin 9 : +V

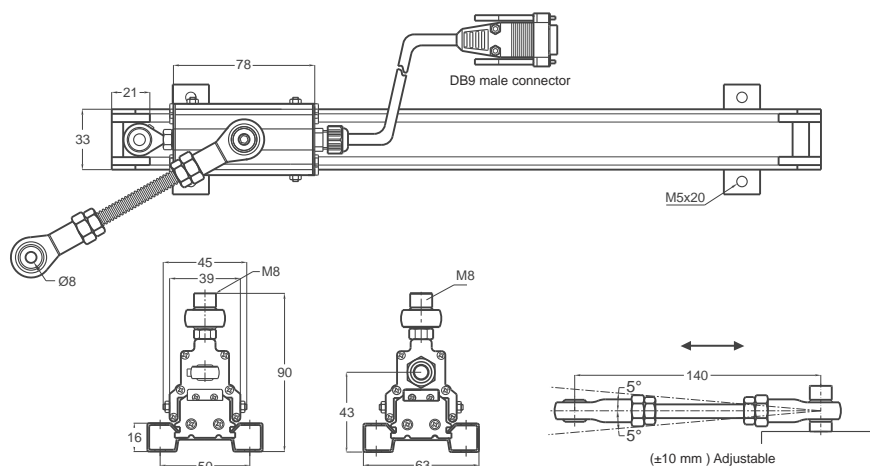

MLIP(mm)	50	100	150	200	250	300	350	400	500	600	700	800	900	1000	1250	1500	1750	2000
US (Usefull Stroke)	50	100	150	200	250	300	350	400	500	600	700	800	900	1000	1250	1500	1750	2000
MS (Mechanical Stroke)	72	122	172	222	272	322	372	422	522	622	722	822	922	1022	1272	1522	1772	2122
L (Total Length)	181	231	281	331	381	431	481	531	631	731	831	931	1031	1131	1381	1631	1881	2131

Model	Measurement stroke	Resolution	Output type	Pole pitch	Output	Supply voltage	Connector / Cable
(example) MLIP	600	T20	LTP	B5	B	V1	2M5
MLIP	50 ... 5000 mm (can be extend up to 50meters)	T10 : 2,5 µm T20 : 5 µm T50 : 12,5 µm T80 : 20 µm T100: 25 µm	LTP : Push-pull TT : TTL Linedriver HLD: High Linedriver	B5 : 5 mm B2 : 2 mm 2B5: 2,56 mm	1Z: Ref. at c. cable side 2Z: Ref. at cable side 3Z: Ref. at middle 5Z: Continues ref. 0Z: Without ref. B : A,B	V1: 5 VDC V2: 8 - 24 VDC	2M5: 2,5 meter cable 9G : G type electrical connection 9H : H type electrical connection

Magnetic Linear Incremental Encoder For Press Brake

- 5 µm resolution, TTL Linedriver output
- Measuring range 150 - 720 mm (other options on request)
- Magnetic contactless measurement
- Protective steel cover for measurement tape
- Teflon guiding system
- Selectable reference position options
- ± 40 µm accuracy

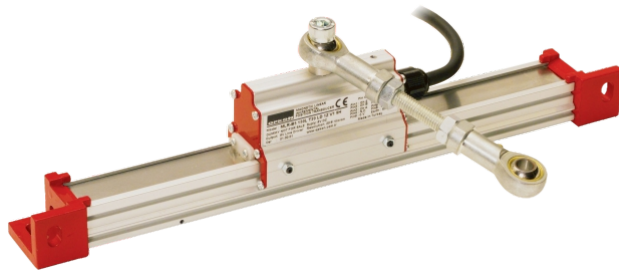

Technical specifications

Type of measurement	Magnetic incremental non-contact
Measurement stroke	150 to 720 mm
Resolution	2,5 / 5 / 10 / 12,5 / 20 / 25 µm
Accuracy	± 40 µm
Output channels	A, \bar{A} , B, \bar{B} , Z, \bar{Z}
Output type	TTL Linedriver
Supply voltage	5 VDC (standard), 8 - 24 VDC (optional)
Power consumption (without load)	< 40 mA (24 VDC)
Electrical connections	DB9 connector with 1 m cable
Max. speed	< 3 m/s
Case material	Anodized aluminium
Mechanical fixing	End-caps on the both side
IP degree	IP 65
Operating temperature	-20°C ... +80°C
Storage temperature	-30°C ... +90°C

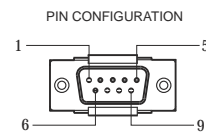
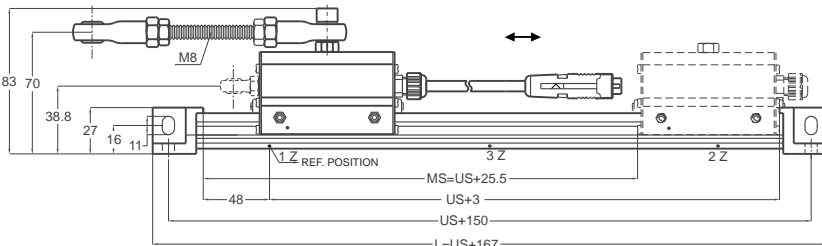

Cable output

- V+ : Brown
- 0V : Blue
- A : Black
- B : White
- Z : Orange
- A inv. : Yellow
- B inv. : Green
- Z inv. : Red
- GND : Earth

9G Type Electrical Connections

- Pin 1 : Ch A
- Pin 2 : Ch A inv.
- Pin 3 : Ch Z
- Pin 4 : Ch B
- Pin 5 : Ch B inv.
- Pin 6 : Ch Z inv.
- Pin 7 : +V
- Pin 8 : GND
- Pin 9 : Shield

9H Type Electrical Connections

- Pin 1 : Ch Z
- Pin 2 : Ch B
- Pin 3 : Ch A
- Pin 4 : NC
- Pin 5 : GND
- Pin 6 : Ch Z inv.
- Pin 7 : Ch B inv.
- Pin 8 : Ch A inv.
- Pin 9 : +V

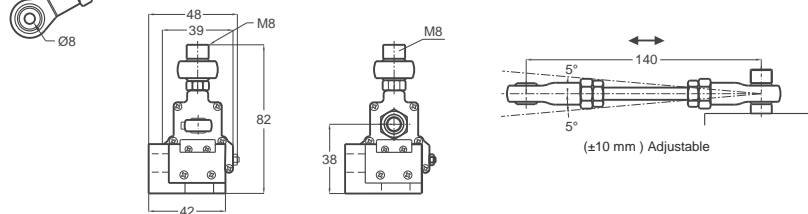
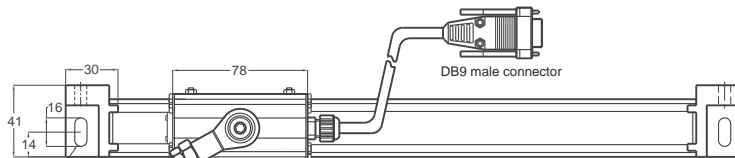

MLR (mm)	150	170	220	270	320	370	420	470	520	570	620	670	720
US (Usefull Stroke)	153	173	223	273	323	373	423	473	523	573	623	673	723
MS (Mechanical Stroke)	178.5	198.5	248.5	298.5	348.5	398.5	448.5	498.5	548.5	598.5	648.5	698.5	748.5
L (Total Length)	317	337	387	437	487	537	587	637	687	737	787	837	887

Model	Pole pitch	Stroke	Resolution	Output type	Output	Supply voltage	Connector / Cable
(example) MLR	B5	270R	T20 (4x mode)	TT	Z	V1	9G
MLR	B2: 2mm pole pitch B5: 5mm pole pitch	270R: 270 mm right 270L: 270 mm left (150 ... 720 mm strokes)	T10 : 2,5 µm T20 : 5 µm T40 : 10 µm T50 : 12,5 µm T80 : 20 µm T100: 25 µm	TT : TTL Linedriver LTP: Push-Pull HLD: HTL Linedriver	1Z: Ref. at c. cable side 2Z: Ref. at cable side 3Z: Ref. at middle 5Z: Continues ref. 0Z: Without ref. Z: A,B,Z	V1: 5 VDC V2: 8-24 VDC	9G : 9 pin connector with 1 meter cable (standard) 9H : 9 pin connector with 1 meter cable (standard)

Spring type magnetic linear incremental encoder

- 10 µm accuracy
- 15 mm measurement stroke
- 1024 puls / mm resolution
- Magnetic, incremental
- Push-Pull and Linedriver output
- IP 65 protection
- Internal spring loaded
- Quality Control and for Test Application



Technical specifications

Type of measurement	Magnetic, incremental
Measurement stroke	15 mm
Resolution	1024 puls / mm
Accuracy	± 10 µm
Output channels	A, B,
Output type	Push-Pull, Linedriver, HLD (HTL Linedriver)
Supply voltage	8 - 24 VDC
Power consumption (without load)	< 50 mA
Electrical connection	4 pin connector
Max. speed	< 3 m/s
Case material	Anodized aluminium
IP degree	IP 65
Operating temperature	-20°C ... +80°C
Storage temperature	-30°C ... +90°C

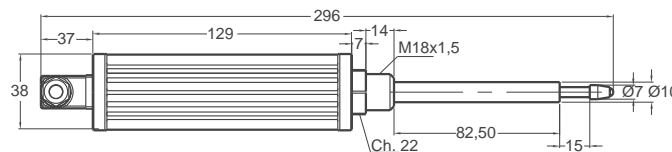

Hydraulic type connector configuration

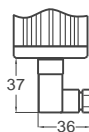

5 pin connector configuration

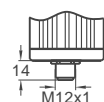

8 pin connector configuration

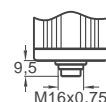

Cable configuration

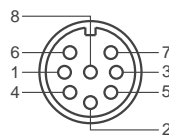
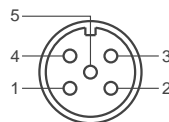
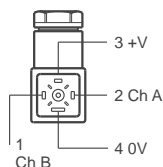

Linedriver Cable Output

- Ch A : Black
- Ch A inv. : Yellow
- Ch B : White
- Ch B inv. : Green
- Ch Z : Orange
- Ch Z inv. : Red
- +V : Brown
- 0V : Blue
- GND : Shield

Push-Pull Cable Output

- Ch A : Black
- Ch B : White
- Ch Z : Orange
- +V : Brown
- 0V : Blue
- GND : Shield

Model	Measurement stroke	Resolution	Output type	Pole pitch	Output	Supply voltage	Connector / Cable
(example) MLCS	15	TX	LTP	5	B	V1	2M5
MLCS	15 mm	TX: 1024 puls/mm	LTP : Push-Pull LD : Linedriver HLD: HTL Linedriver	5: 5mm pole pitch	B: Without ref.	V1: 5 VDC V2: 8-24 VDC	2M5: 2.5 meter cable 5M : 5 meter cable C5 : 5 pin connector C8 : 8 pin connector

Linear Potentiometers
Linear Potentiometers Slim Body Series
Linear Potentiometers Conditioner Circuit
Magnetostrictive Position Sensors
Magnetic Linear Incremental Encoders
Draw Wire Potentiometers/Encoders
Optic Rotary Absolute Encoders
Magnetic Rotary Encoders
Optic Rotary Incremental Encoders

Draw Wire Encoder



Measuring strokes 500 - 1000 - 1500 - 2000 - 2500 - 3000 - 3500 - 3600 mm
 0,1 mm/ppr. and 0,2 mm/ppr. resolution
 Push-Pull, TTL Linedriver or HTL Linedriver
 Easy mounting
 High protection degree

Technical Specifications

Type of Measurement	Optical
Resolution	0,1 mm/ppr - 0,2 mm/ppr.
Measurement Stroke	500 to 3600 mm
Output Signal	A,B,Z or A,Ā, B,Ā, Z, Z̄
Output Signal Type	Push-Pull, TTL Linedriver or HTL Linedriver
Supply Voltage	8 - 24 VDC, 5 VDC or 5 - 30 VDC
Power Consumption (without load)	< 40 mA (24 VDC)
Electrical Connections	2.5 m cable (standard)
IP Degree	IP 54
Case Material	Aluminium / Steel / ABS plastic
Operating Temperature	-20°C ... +80°C
Storage Temperature	-30°C ... +90°C

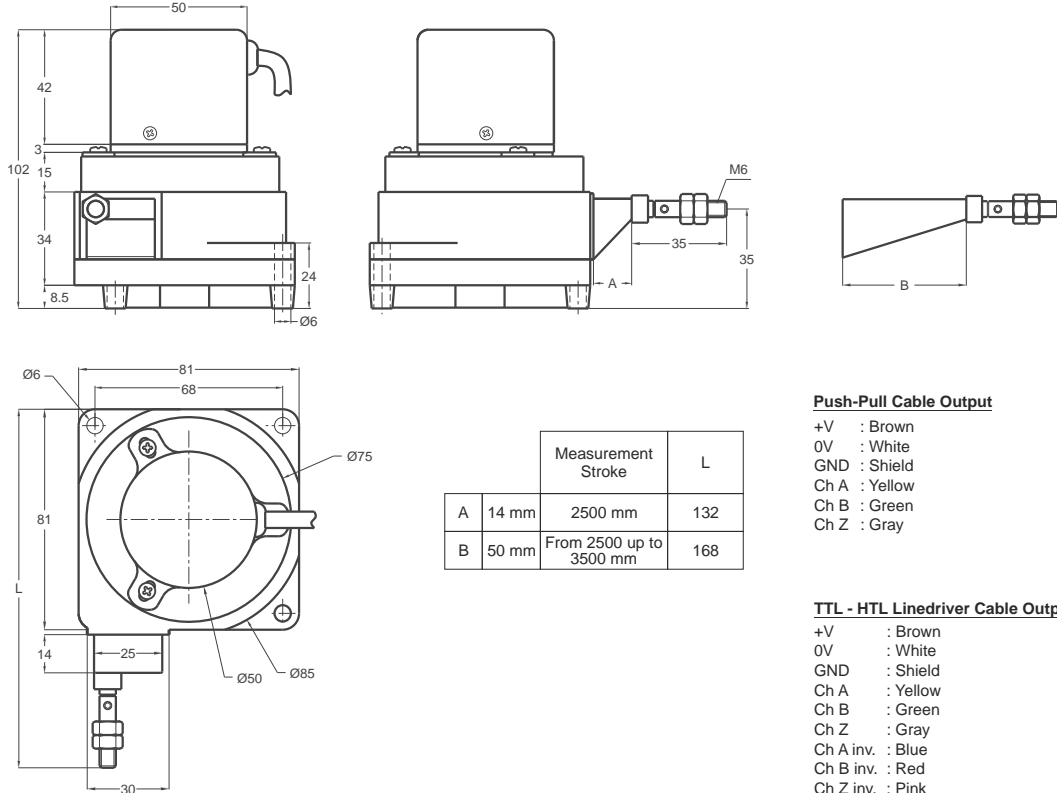

Push-Pull Cable Output

+V : Brown
 0V : White
 GND : Shield
 Ch A : Yellow
 Ch B : Green
 Ch Z : Gray

TTL - HTL Linedriver Cable Output

+V : Brown
 0V : White
 GND : Shield
 Ch A : Yellow
 Ch B : Green
 Ch Z : Gray
 Ch A inv. : Blue
 Ch B inv. : Red
 Ch Z inv. : Pink

Model	Measurement Stroke	Output	Resolution	Output Signal	Connector / Cable	Cable Output
(example) DWE	1500	LTP	P2000	Z	2M5	R
DWE	500 mm 3000 mm 1000 mm 3500 mm 1500 mm 3600 mm 2000 mm 2500 mm	LTP : Pushpull TTL : TTL Linedriver HLD: High Linedriver	P2000: 0,1 mm/puls P1000: 0,2 mm/puls	Z: A,B,Z B: A,B	2M5: 2,5 meter cable 5M : 5 meter cable 8M : 8 meter cable 10M: 10 meter cable	R: Radial A: Axial

Draw Wire Potentiometer

Measuring strokes 500, 900, 1800 or 3600 mm
 5 kOhm / 10 kOhm resistive type or with
 internal voltage / current conditioner circuit
 Easy mounting



Technical Specifications

Type of Measurement	Resistive type
Linearity	0,5%, 0,1% or 0,05%
Measurement Stroke	500, 900, 1800 or 3600 mm
Output Signal Type	Voltage divider
Output Type	Resistive output, 0 - 10 V or 0 - 20 mA or 4 - 20 mA
Supply Voltage	24 VDC max., 15 - 30 V (voltage / current output)
Electrical Connections	2.5 m cable (standard)
Case Material	Aluminium / Steel / ABS plastic
IP Degree	IP 54
Operating Temperature	-20°C ... +80°C
Storage Temperature	-30°C ... +90°C

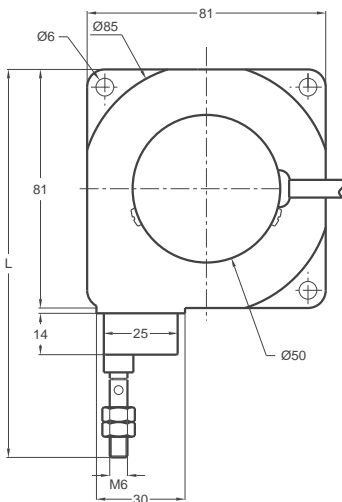
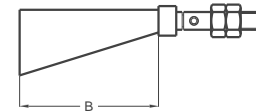
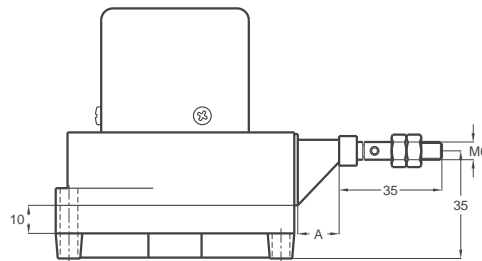
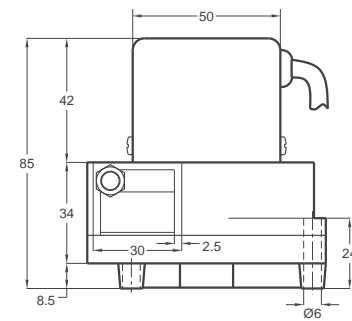

	Measurement Stroke	L
A	14 mm	1800 mm
B	50 mm	3600mm

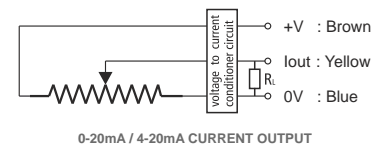
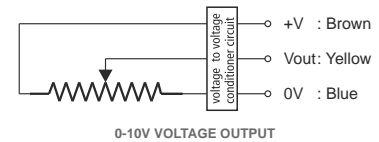
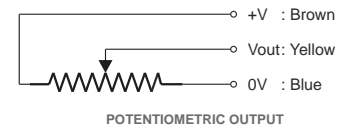

Model	Measurement Stroke	Linearity	Output	Connector / Cable	Cable Output
(example) DWP	1800	C	5K	2M5	R
DWP	500 mm 900 mm 1800 mm 3600 mm	C: 0,5% D: 0,1%	5K: 5 10K: 10 V10: 0-10 V I 4 : 4-20 mA I 20: 0-20 mA 20K: 3600	2M5: 2,5 meter cable 5M : 5 meter cable 8M : 8 meter cable 10M: 10 meter cable	R: Radial

Linear Potentiometers
 Linear Potentiometers Slim Body Series
 Linear Potentiometers Conditioner Circuit
 Magnetostrictive Position Sensors
 Magnetic Linear Incremental Encoders
 Draw Wire Potentiometers/Encoders
 Optic Rotary Absolute Encoders
 Magnetic Rotary Encoders
 Optic Rotary Incremental Encoders

ERC10 BISS ERC10 SSI

BISS / SSI Interface Encoder

- Feedback encoder for synchronous gearless motors
- BISS or SSI interface
- Optical absolute encoder
- Absolute 13 bit rotor feedback data (max. 21 bit)
- Additional 1 Vpp/2048 ppr SinCos incremental signals
- Physically compatible with SSI and EnDat layer
- Fast transmission rates at 10 Mhz clock frequency
- Protected data transmission with CRC sum. (failure check)



Technical Specifications

Interface	BISS / SSI (up to 10 Mhz)
Clock input	via full duplex I.C
Clock frequency	20 kHz up to 10 Mhz
Data output driver	RS485 transceiver type
Data output code	gray or binary
Supply voltage	5 - 20 VDC ±%5
Current consumption	130 mA max.
Resolution	13 bit (up to 21 for BISS)
Output circuit	BISS / SSI interface
Pulse frequency	< 200 kHz
Working principal	optical
Accuracy	<2048 / ±40°
Incremental channels	A, A inv. B, B inv. (sine 1 Vpp)
Flange	special motor feedback flange
Case diameter	Ø56 mm
Shaft diameter	Cone 1/10
Shaft axial / radial loading	30 N max.
Starting torque	0,17 Ncm min.
Electrical connections	18 pin pcb type connector or DB15 connector with 20 cm cable
Weight	340 gr. (without cable)
Shock	100 g, 5 ms
Vibrations	10 g, 5-2000 Hz
Protection	IP47
Operating temperature range	-20°C ... +85°C
Storage temperature range	-20°C ... +85°C

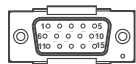

D-SUB15 Connector Male (C15)

PIN CONFIGURATION

PIN	COLOR	FUNCTION
1	Red - Black	B ⁻
2	NC	
3	NC	
4	NC	
5	Green - Black	A ⁺
6	Yellow - Black	A ⁻
7	Green - White	0V
8	Blue - Black	B ⁺
9	Green - Brown	5V
10	Yellow	CLK ⁻
11	Purple	CLK ⁺
12	Gray	DATA ⁺
13	Pink	DATA ⁻
14	NC	
15	Inner Shield	
	Cover	Outer Shield

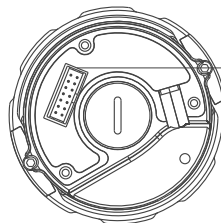
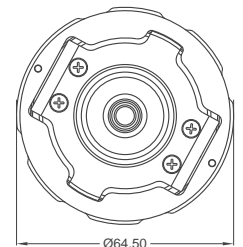
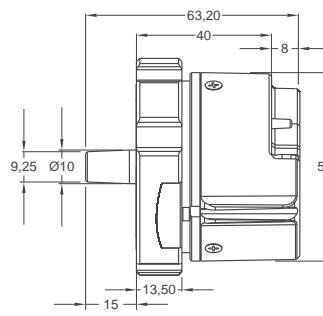
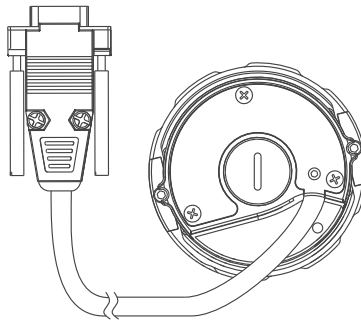

On Board Connector Male (C14)

PIN CONFIGURATION

PIN	COLOR	FUNCTION
1A	Yellow	CLK ⁻
1B	Brown - Green	+V
2A	Yellow - Black	A ⁻
2B	Gray	DATA ⁺
3A	N.C.	GND Sense
3B	Blue - Black	B ⁺
4A	Black	NC
4B	Red	NC
5A	Red - Black	B ⁻
5B	White - Green	GND
6A	Pink	DATA ⁻
6B	Green - Black	A ⁺
7A	N.C.	+V Sense
7B	Purple	CLK ⁺

Model	Case Diameter	Case Type	Shaft Diameter	Interface	Resolution	Output Channels	Supply Voltage	Connector / Cable
(example) PRA	56	ERC	10	BSB	2048	VP	V1	0m5 C15
PRA	56mm	ERC	10	BSB : BISS Binary BSG : BISS Gray SSIB : SSI Binary SSIG : SSI Gray	2048	VP : 1 Vpp LD : RS422 TTL VPLD: 1 Vpp + RS422 TTL	V1: 5 VDC	0m5 C15 C14

Sine-Wave Encoder with Commutation Signals

- Feedback encoder for synchronous gearless motors
- Optical absolute encoder
- 1 Vpp/2048 ppr SinCos incremental signals (A,B)
- Additional 1 Vpp/1 ppr absolute commutation signals (C,D)
- User friendly installation
- Rigid shaft coupling



Technical Specifications

Supply voltage	5 - 20 VDC ±%5
Current consumption (without load)	130 mA max. (without load)
Resolution	2048 ppr.
Output circuit	Analogue
Pulse frequency	< 200 kHz
Working principle	Optical
Accuracy	<2048 / ±40"
Incremental channels	A, A inv. B, B inv. / 2048 ppr. (sine 1 Vpp)
Absolute channels	C, C inv. D, D inv. / 1 ppr. (sine 1 Vpp)
Flange	Special motor feedback flange
Case diameter	Ø56 mm
Shaft diameter	cone 1/10
Shaft axial / radial loading	30 N max.
Starting torque	0,17 Ncm min.
Electrical connections	18 pin pcb type connector or DB15 connector with 20 cm cable
Weight	340 gr. (without cable)
Shock	100 g, 5 ms
Vibrations	10 g, 5-2000 Hz
Protection	IP47
Operating temperature range	-20°C +85°C
Storage temperature range	-20°C +85°C

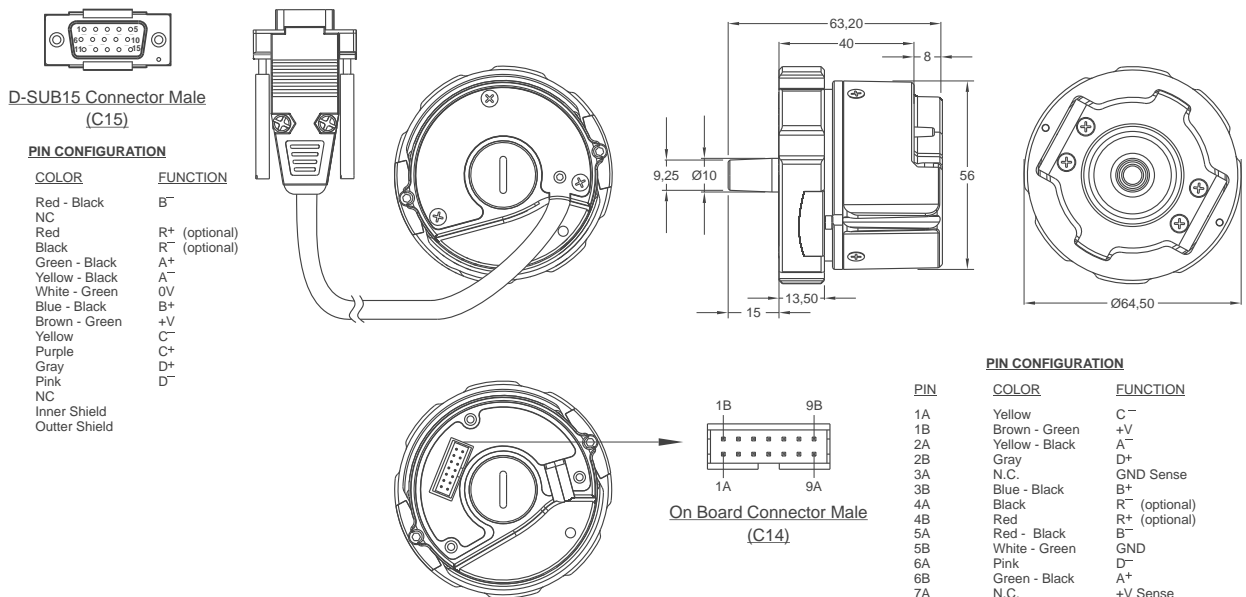

Model	Case Diameter	Case Type	Shaft Diameter	Interface	Resolution	Output Channels	Supply Voltage	Connector / Cable
(example) PRA	56	ERC	10	SC	2048	VP	V1	0m5 C15
PRA	56mm	ERC	10	SC: sine / cosine	2048	VP: 1Vpp	V1: 5VDC	0m5 C15

Linear Potentiometers
Linear Potentiometers Slim Body Series
Linear Potentiometers Conditioner Circuit
Magnetostrictive Position Sensors
Magnetic Linear Incremental Encoders
Draw Wire Potentiometers/Encoders
Optic Rotary Absolute Encoders
Magnetic Rotary Encoders
Optic Rotary Incremental Encoders

MRI 40A

Magnetic Incremental Encoder

40 mm case diameter

Magnetic incremental encoder

4 - 8 - 16 - 20 - 25 - 32 - 40 - 50 - 64 - 80 - 100 - 125,

128 - 160 - 200 - 250 - 256 - 400 - 500 - 512 ppr.

IP 54 protection



Technical Specifications

Type of Measurement	Magnetic incremental contactless
Resolution	4 to 512 ppr.
Output Channels	A,B,Z or A, \bar{A} , B, \bar{B} , Z, \bar{Z}
Output Type	Push-Pull, TTL Linedriver or HTL Linedriver
Supply Voltage	8 - 24 VDC (standard) or 5 VDC (optional)
Power Consumption (without load)	< 40 mA (24 VDC)
Electrical Connections	2.5 m (standard)
Max. Permissible Shaft Loading	Radial 100 N Axial 60 N
Max. Speed	3500 rpm
Shaft Diameter	Ø4 - 6 - 8 mm
Shaft Material	Stainless steel
Case Diameter	Ø40 mm
Case Material	Aluminium / Steel
IP Degree	IP 54
Operating Temperature	-20°C ... +80°C
Storage Temperature	-30°C ... +90°C

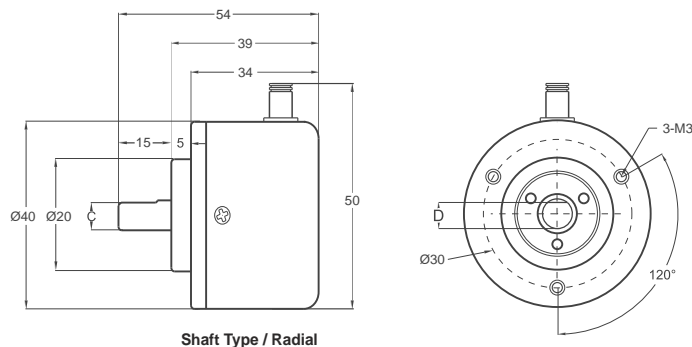

Shaft Type / Radial

MRI 40	R (shaft)	
	C	D
	Ø4 mm	3.30 mm
	Ø6 mm	5.50 mm
	Ø8 mm	7.30 mm

Push-Pull / TTL Linedriver Cable Output

+V : Brown
0V : White
GND : Shield
Ch A : Yellow
Ch B : Green
Ch Z : Gray
Ch A inv. : Blue
Ch B inv. : Red
Ch Z inv. : Pink

HTL Linedriver Cable Output

+V : Brown
0V : White
GND : Shield
Ch A : Yellow
Ch B : Green
Ch Z : Gray
Ch A inv. : Blue
Ch B inv. : Red
Ch Z inv. : Pink

Model	Case Diameter	Case Type	Shaft Diameter	Output	Resolution	Output Channels	Supply Voltage	Connector / Cable	Cable Output
(example) MRI	40	A	R6	HLD	500	Z	V2	2M5	R
MRI	40mm	A : Clamping flange AW: Water proof	R4: 4mm R6: 6mm R8: 8mm	LTP : Push-Pull TTL : TTL Linedriver HLD: High Linedriver	4 ... 512 ppr.	Z: A,B,Z B: A,B	V1: 5 VDC V2: 8-24 VDC	2M5: 2,5 meter cable 5M : 5 meter cable 8M : 8 meter cable 10M: 10 meter cable C12: 12 pin connector	R : Radial A : Axial

Magnetic Incremental Encoder

50 mm case diameter
 Magnetic incremental encoder
 4 - 8 - 16 - 20 - 25 - 32 - 40 - 50 - 64 - 80 - 100 - 125,
 128 - 160 - 200 - 250 - 256 - 400 - 500 - 512 ppr.
 IP 54 protection



Technical Specifications

Type of Measurement	Magnetic incremental contactless
Resolution	4 ... 512 ppr.
Output Channels	A,B,Z or A,Ā, B,Ā, Z, Z̄
Output Type	Push-Pull, TTL Linedriver or HTL Linedriver
Supply Voltage	8 - 24 VDC (standard) or 5 VDC (optional)
Power Consumption (without load)	< 40 mA (24 VDC)
Electrical Connections	2.5 m cable (standard)
Max. Permissible Shaft Loading Radial	100 N
Axial	60 N
Max. Speed	3500 rpm
Shaft Diameter	Ø6 - 8 - 10 mm
Shaft Material	Stainless steel
Case Diameter	Ø50 mm
Case Material	Aluminium / Steel
IP Degree	IP 54
Operating Temperature	-20°C ... +80°C
Storage Temperature	-30°C ... +90°C

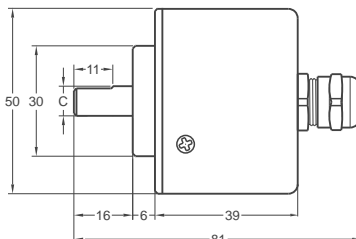

Shaft Type / Axial

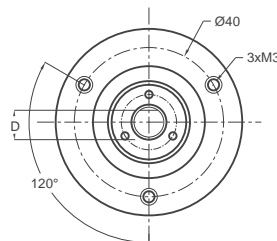

Push-Pull / TTL Linedriver Cable Output

+V : Brown
 0V : White
 GND : Shield
 Ch A : Yellow
 Ch B : Green
 Ch Z : Gray
 Ch A inv. : Blue
 Ch B inv. : Red
 Ch Z inv. : Pink

HTL Linedriver Cable Output

+V : Brown
 0V : White
 GND : Shield
 Ch A : Yellow
 Ch B : Green
 Ch Z : Gray
 Ch A inv. : Blue
 Ch B inv. : Red
 Ch Z inv. : Pink

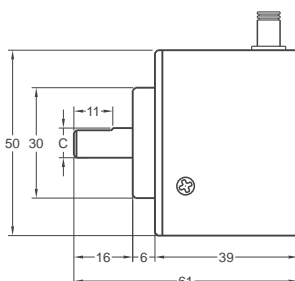

Shaft Type / Radial

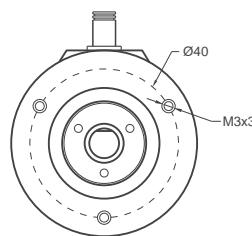

MRI 50	R (shaft)	
	C	D
	Ø6 mm	5,50 mm
	Ø8 mm	7,30 mm
	Ø10 mm	9,00 mm

Model	Case Diameter	Case Type	Shaft Diameter	Output	Resolution	Output Channels	Supply Voltage	Connector / Cable	Cable Output
(example) MRI	50	A	R6	HLD	500	Z	V2	2M5	R
MRI	50mm	A : Clamping flange AW: Water proof	R6 : 6mm R8 : 8mm R10: 10mm	LTP : Push-Pull LD : TTL Linedriver HLD: HTL Linedriver	4 ... 512 ppr.	Z: A,B,Z B: A,B	V1: 5 VDC V2: 8-24 VDC	2M5: 2,5 meter cable 5M : 5 meter cable 8M : 8 meter cable 10M: 10 meter cable	R: Radial A: Axial

Magnetic Incremental Encoder Semi Hollow Shaft

50 mm case diameter
Semi hollow shaft
4 - 8 - 16 - 25 - 32 - 40 - 50 - 64 - 80 - 100 - 125,
128 - 160 - 200 - 250 - 256 - 400 - 500 - 512 ppr.
Push-Pull, TTL Linedriver and HTL Linedriver outputs
Shaft diameter 6 - 8 - 10 - 12 - 14 - 15 mm
3500 rpm max.



Technical Specifications

Type of Measurement	Magnetic incremental contactless
Resolution	4 ... 512 ppr.
Output Channels	A,B,Z or A,Ā, B,Ā, Z, Z̄
Output Type	Push-Pull, TTL Linedriver or HTL Linedriver
Supply Voltage	8 - 24 VDC (standard) or 5 VDC (optional)
Power Consumption (without load)	< 40 mA (24 VDC)
Electrical Connections	2.5 m cable (standard)
Max. Permissible Shaft Loading	Radial 100 N Axial 60 N
Max. Speed	3500 rpm
Shaft Diameter	Ø6 - 8 - 10 - 12 - 14 - 15 mm
Shaft Material	Stainless steel
Case Diameter	Ø50 mm
Case Material	Aluminium / Steel
IP Degree	IP 54
Operating Temperature	-20°C ... +80°C
Storage Temperature	-30°C ... +90°C

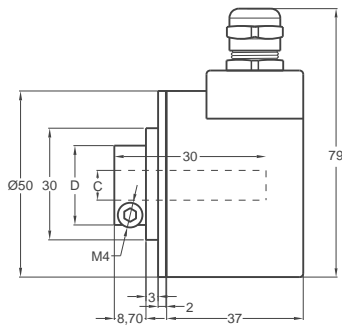

SH Type (Radial)

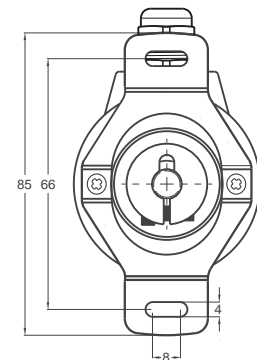
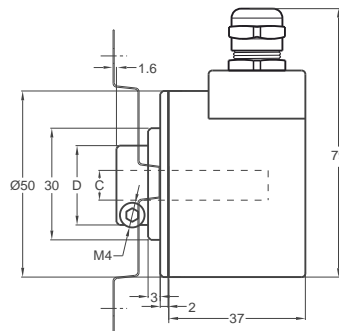

MRI 50SH	SH (semi hollow)	
	C	D
	Ø6 mm	20 mm
	Ø8 mm	22 mm
	Ø10 mm	23,5 mm
	Ø12 mm	23,5 mm
	Ø14 mm	29,5 mm
	Ø15 mm	29,5 mm

Push-Pull Cable Output

+V : Brown
0V : White
GND : Shield
Ch A : Yellow
Ch B : Green
Ch Z : Gray

TTL - HTL Linedriver Cable Output

+V : Brown
0V : White
GND : Shield
Ch A : Yellow
Ch B : Green
Ch Z : Gray
Ch A inv.: Blue
Ch B inv.: Red
Ch Z inv.: Pink

Model	Case Diameter	Case Type	Shaft Diameter	Output Type	Resolution	Output Channels	Supply Voltage	Connector / Cable	Cable Output
(example) MRI	50	SH	8	HLD	1024	Z	V2	2M5	R
MRI	50mm	SH : Semi hollow	6 : 6mm 8 : 8mm 10 : 10mm 12 : 12mm 14 : 14mm 15 : 15mm	LTP : Push-Pull LD : TTL Linedriver HLD : HTL Linedriver	4 ... 512ppr.	Z : A, B, Z B : A, B	V1 : 5V DC V2 : 8-24V DC V3 : 5-24V DC	2M5 : 2,5 meter cable 5M : 5 meter cable 8M : 8 meter cable 10M : 10 meter cable	R : Radial

Magnetic Incremental Encoder

58 mm case diameter
Magnetic incremental rotary encoder
4 - 8 - 16 - 25 - 32 - 40 - 50 - 64 - 80 - 100 - 125,
128 - 160 - 200 - 250 - 256 - 400 - 500 - 512 ppr.
Very useful for outdoor applications

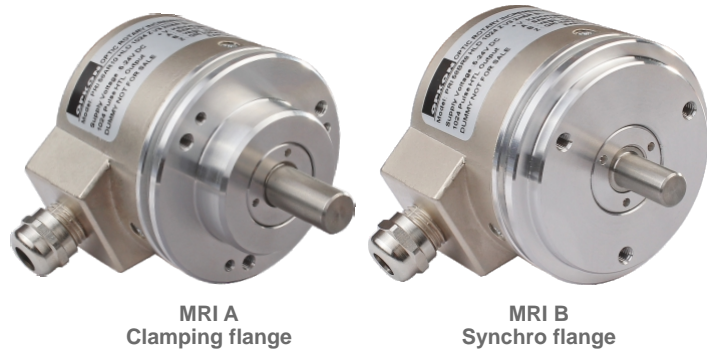

MRI A
Clamping flange

MRI B
Synchro flange

Technical Specifications

Type of Measurement	Magnetic incremental non-contact
Resolution	4 ... 512 ppr.
Output Channels	A,B,Z or A,Ā, B,Ā, Z,Z̄
Output Type	Push-Pull, TTL Linedriver, HTL Linedriver
Supply Voltage	5 VDC, 8 - 24 VDC, 5 - 24 VDC
Power Consumption	< 40 mA (24 VDC)
Electrical Connections	2.5 m cable (standard)
Max. Permissible Shaft Loading Radial	60 N
Axial	40 N
Max. Speed	3500 rpm
Shaft Diameter	Ø6 - 8 - 10 mm
Shaft Material	Stainless steel
Case Diameter	Ø58 mm
Case Material	Aluminium / Steel
IP Degree	IP 54
Operating Temperature	-20°C ... +80°C
Storage Temperature	-30°C ... +90°C

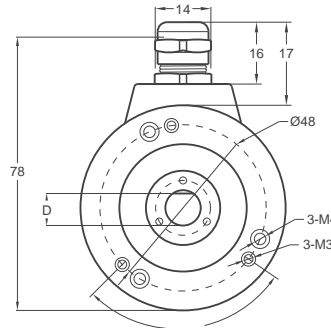
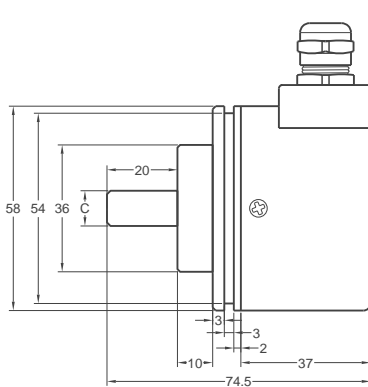

A Type (Clamping flange)

Push-Pull Cable Output

- +V : Brown
- 0V : White
- GND : Shield
- Ch A : Yellow
- Ch B : Green
- Ch Z : Gray

TTL - HTL Linedriver Cable Output

- +V : Brown
- 0V : White
- GND : Shield
- Ch A : Yellow
- Ch B : Green
- Ch Z : Gray
- Ch A inv. : Blue
- Ch B inv. : Red
- Ch Z inv. : Pink

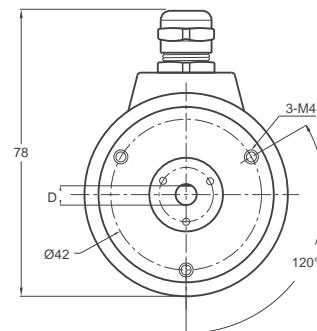
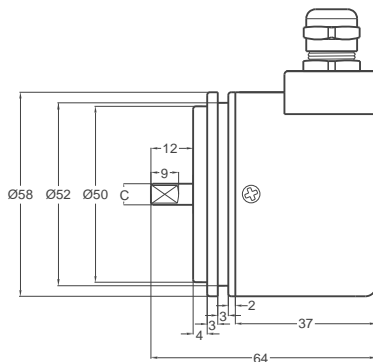

B Type (Synchro Flange)

PRI 58	AR (shaft)		BR (shaft)	
	C	D	C	D
	Ø6 mm	5 mm	Ø6 mm	5 mm
	Ø8 mm	7 mm	Ø8 mm	7 mm
	Ø10 mm	9 mm	Ø10 mm	9 mm

Model	Case Diameter	Case Type	Shaft Diameter	Output	Resolution	Output Channels	Supply Voltage	Connector / Cable	Cable Output
(example) MRI	58	A	R8	HLD	512	ZZ	V2	2M5	R
MRI	58mm	A : Clamping flange AW: Water proof B : Synchro flange BW: Water proof	R6 : 6mm R8 : 8mm R10: 10mm	LTP : Push-Pull LD : TTL Linedriver HLD: HTL Linedriver	4 ... 512 ppr.	Z : A,B,Z ZZ: AA, BB, ZZ	V1: 5 VDC V2: 8-24 VDC	2M5: 2,5 meter cable 5M : 5 meter cable 8M : 8 meter cable 10M: 10 meter cable	R: Radial A: Axial

Linear Potentiometers
Linear Potentiometers Slim Body Series
Linear Potentiometers Conditioner Circuit
Magnetostrictive Position Sensors
Magnetic Linear Incremental Encoders
Draw Wire Potentiometers/Encoders
Optic Rotary Absolute Encoders
Magnetic Rotary Encoders
Optic Rotary Incremental Encoders

MRV 50A

Magnetic Absolute Encoder Voltage Output

50 mm case diameter

Magnetic absolute rotary encoder

$V_{OUT}/360^\circ$ (standard), $V_{OUT}/45^\circ, 90^\circ, 180^\circ$

$I_{OUT}/360^\circ$ (standard), $I_{OUT}/45^\circ, 90^\circ, 180^\circ$

IP 54 protection

Can be used as contactless potentiometer



Technical Specifications

Type of Measurement	Magnetic absolute
Resolution	5V/360° (standard) 5V/45°, 90°, 180° / 10V/360° (standard) 10V/45°, 90°, 180°
Output Signal	Analogue
Output Type	Voltage output (0-5 VDC or 0-10 VDC) / Current output (0-20 mA or 4-20 mA)
Supply Voltage	8-24 VDC (0-5 VDC standard) 15-30 VDC (0-10 VDC standard) 15-30 VDC (0-20 mA/4-20 mA standard for current output)
Power Consumption (without load)	< 40 mA (24 VDC)
Electrical Connections	2.5 m cable (standard)
Max. Permissible Shaft Loading Radial	100 N
Axial	60 N
Max. Speed	1000 rpm
Shaft Diameter	Ø8 mm
Shaft Material	Stainless steel
Case Diameter	Ø50 mm
Case Material	Aluminium / Steel
IP Degree	IP 54
Operating Temperature	-20°C ... +80°C
Storage Temperature	-30°C ... +90°C

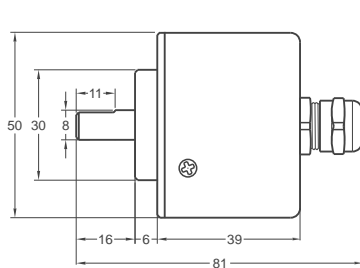

Shaft Type / Axial

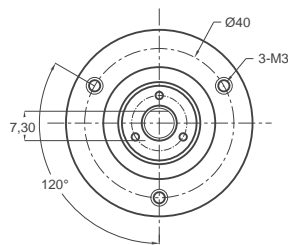

Cable output

+V : Brown
0V : White
Vout : Yellow
GND : Shield

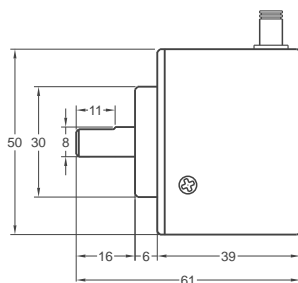

Shaft Type / Radial

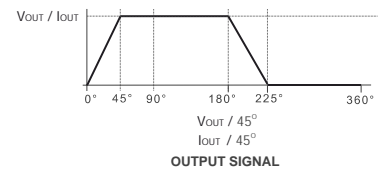
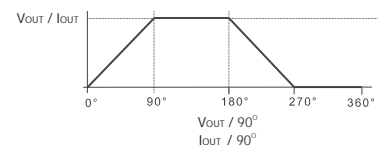
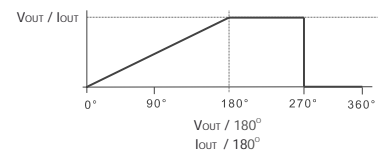
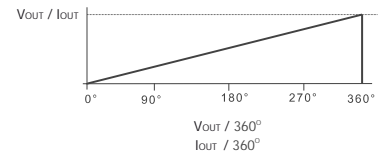
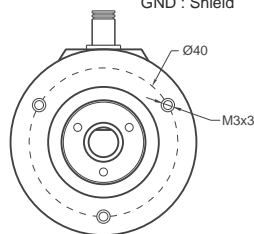

OUTPUT SIGNAL

Model	Case Diameter	Reference	Supply Voltage	Connector / Cable	Cable Output
(example) MRV	50A	5 V/360°	V2	2M5	R
MRV	50A : Standard case 50AW: Water proof	5 V / 360° 5 V / 180° 5 V / 90° 5 V / 45° 10 bit	V1: 5 VDC V2: 8-24 VDC	2M5: 2.5 meter cable 5M : 5 meter cable 8M : 8 meter cable 10M: 10 meter cable	R: Radial A: Axial

Magnetic Absolute Encoder SSI Output

50 mm case diameter
 Magnetic absolute rotary encoder
 SSI Absolute (10 bit / 360°)
 2.5m cable (standard) with connector (Optional) electrical connection



Technical Specifications

Type of Measurement	Magnetic absolute
Resolution	10 bit / 360°
Output Type	SSI
Output Signal Type	5 V TTL
Supply Voltage	8 - 24 VDC (standard) or 5 VDC (optional)
Power Consumption (without load)	< 40 mA (24 VDC)
Electrical Connections	2.5 m cable (standard), connector (optional)
Max. Permissible Shaft Loading Radial	100 N
Axial	60 N
Max. Speed	1000 rpm
Rod Diameter	Ø8 mm
Rod Material	Stainless steel
Case Diameter	Ø50 mm
Case Material	Aluminium / Steel
Operating Temperature	-20°C ... +80°C
Storage Temperature	-30°C ... +90°C

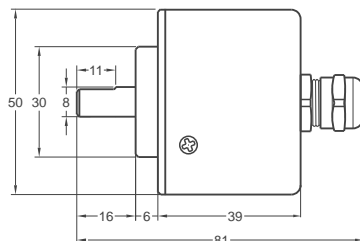

Mil Type / Axial

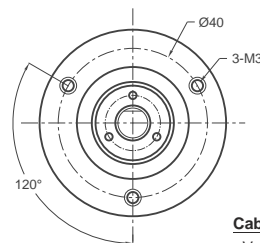

Cable Output

+V : Brown
 0V : White
 CLK: Green
 CSN: Yellow
 DO : Gray

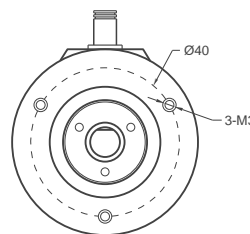
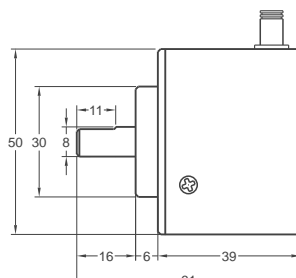

Model	Case Diameter	Output Signal Type	Output Type	Supply Voltage	Connector / Cable	Cable Output
(example) MRA	50A	TT	SSI	V1	2M5	R
MRA	50A : Clamping flange 50AW: Water proof	TT: TTL Absolute	SSI	V1: 5 VDC V2: 8-24 VDC	2M5: 2,5 meter cable 5M : 5 meter cable 8M : 8 meter cable 10M: 10 meter cable	R: Radial A: Axial

Optic Rotary Incremental Encoder

40 mm case diameter
 100 - 200 - 250 - 300 - 360 - 400 - 500 - 512 - 600 - 1000 - 1024 - 1250 ppr.
 Push-Pull, TTL Linedriver and HTL Linedriver outputs
 Shaft diameter 4 - 6 mm
 3500 rpm max.



Technical Specifications

Resolution	100 to 1250 ppr.
Output Channels	A,B,Z or A,Ā, B,Ā, Z, Z̄
Output Type	Push-Pull, TTL Linedriver, HTL Linedriver
Supply Voltage	5 VDC, 8 - 24 VDC or 5 - 24 VDC
Power Consumption (without load)	< 40 mA (24 VDC)
Cable	1.5m (standard) 5 wire + Shield (Push-Pull) 1.5m (standard) 8 wire + Shield (Linedriver)
Max. Permissible Shaft Loading Radial	80 N
Max. Speed	3500 rpm
Shaft Diameter	Ø4 - 6 mm
Shaft Material	Stainless steel
Case Diameter	Ø40 mm
Case Material	Aluminium and painted steel
IP Degree	IP 54
Operating Temperature	-20°C ... +80°C
Storage Temperature	-30°C ... +90°C

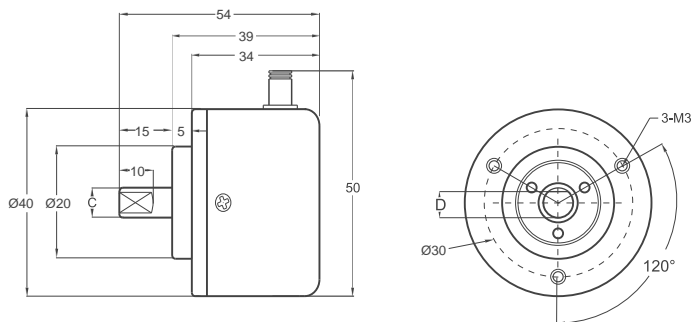

Shaft type / Radial

PRI 40	R (shaft)	
	C	D
	Ø4 mm	3.30 mm
	Ø6 mm	5.30 mm

Push-Pull Cable Output

+V : Brown
 0V : White
 GND : Shield
 Ch A : Yellow
 Ch B : Green
 Ch Z : Gray

TTL - HTL Linedriver Cable Output

+V : Brown
 0V : White
 GND : Shield
 Ch A : Yellow
 Ch B : Green
 Ch Z : Gray
 Ch A inv.: Blue
 Ch B inv.: Red
 Ch Z inv.: Pink

Model	Case Diameter	Case Type	Shaft Diameter	Output Type	Resolution	Output Channels	Supply Voltage	Connector / Cable	Cable Output
(example) PRI	40	A	R6	HLD	1250	Z	V2	2M5	R
PRI	40mm	A: Clamping flange	R4: 4mm R6: 6mm	LTP : Push-Pull LD : TTL Linedriver HLD: HTL Linedriver	100 ... 1250 ppr.	Z :A,B,Z B :Ā,B̄ Z̄: Ā,Ā, Z̄	V1 : 5 VDC V3 : 5-24 VDC	2M5: 2,5 meter cable 5M : 5 meter cable	R: Radial

Optic Rotary Incremental Encoder

50 mm case diameter
 100 - 200 - 360 - 400 - 500 - 600 - 720 - 1000 - 1024
 1800 - 2000 - 2048 - 2500 - 3600 - 4000 - 4096 - 5000 ppr.
 Push-Pull, TTL Linedriver and HTL Linedriver outputs
 Shaft diameter 6 - 8 - 10 mm
 3500 rpm max.



Technical Specifications

Resolution	100 to 5000 ppr.
Output Channels	A,B,Z or A,Ā, B,B̄, Z,Z̄
Output Type	Push-Pull, TTL Linedriver, HTL Linedriver
Supply Voltage	5 VDC, 8 - 24 VDC or 5 - 24 VDC
Power Consumption (without load)	< 40 mA (24 VDC)
Cable	2.5m (standard) 5 wire + Shield (Push-Pull) 2.5m (standard) 8 wire + Shield (Linedriver)
Max. Permissible Shaft Loading Radial	100 N
Axial	60 N
Max. Speed	3500 rpm
Shaft Diameter	Ø6 - 8 - 10 mm
Shaft Material	Stainless steel
Case Diameter	Ø50 mm
Case Material	Aluminium and painted steel
IP Degree	IP 54
Operating Temperature	-20°C ... +80°C
Storage Temperature	-30°C ... +90°C

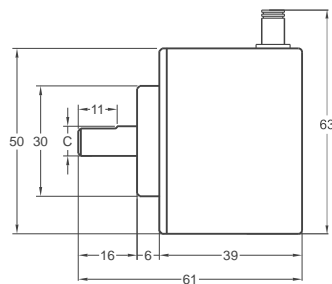

Shaft Type / Radial

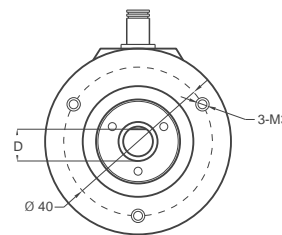

PRI 50	R (shaft)	
	C	D
	Ø6 mm	5,50 mm
	Ø8 mm	7,30 mm
	Ø10 mm	9,00 mm

Push-Pull Cable Output

+V : Brown
 0V : White
 GND: Shield
 Ch A: Yellow
 Ch B: Green
 Ch Z: Gray

TTL - HTL Linedriver Cable Output

+V : Brown
 0V : White
 GND : Shield
 Ch A : Yellow
 Ch B : Green
 Ch Z : Gray
 Ch A inv.: Blue
 Ch B inv.: Red
 Ch Z inv.: Pink

Model	Case Diameter	Case Type	Shaft Diameter	Output Type	Resolution	Output Channels	Supply Voltage	Connector / Cable	Cable Output
(example) PRI	50	A	R6	HLD	1024	Z	V2	2M5	R
PRI	50mm	A: Clamping flange	R6 : 6 mm R8 : 8 mm R10: 10 mm	LTP : Push-Pull LD : TTL Linedriver HLD: HTL Linedriver	100 ... 5000 ppr.	Z: A,B,Z B: A,B	V1: 5 VDC V2: 8-24 VDC V3: 5-24 VDC	2M5: 2,5 meter cable 5M : 5 meter cable 8M : 8 meter cable 10M: 10 meter cable	R: Radial

Linear Potentiometers
 Linear Potentiometers Slim Body Series
 Linear Potentiometers Conditioner Circuit
 Magnetostrictive Position Sensors
 Magnetic Linear Incremental Encoders
 Draw Wire Potentiometers/Encoders
 Optic Rotary Absolute Encoders
 Magnetic Rotary Encoders
 Optic Rotary Incremental Encoders

PRI 58A PRI 58B

Optic Rotary Incremental Encoder

58 mm case diameter
 100 - 200 - 360 - 400 - 500 - 600- 720 - 1000 - 1024
 1800 - 2000 - 2048 - 2500 - 3600 - 4000 - 4096 - 5000 ppr.
 Push-Pull, TTL Linedriver and HTL Linedriver outputs
 Shaft diameter 6 - 8 - 10 mm
 3500 rpm max.



PRI A
Clamping flange

PRI B
Synchro flange

Technical Specifications

Resolution	100 to 5000 ppr.
Output Channels	A,B,Z or A, \bar{A} , B, \bar{B} , Z, \bar{Z}
Output Type	Push-Pull, TTL Linedriver, HTL Linedriver
Supply Voltage	5 VDC or 8 - 24 VDC or 5 - 24 VDC
Power Consumption (without load)	< 40 mA (24 VDC)
Cable	2.5m (standard) 5 wire + Shield (Push-Pull) 2.5m (standard) 8 wire + Shield (Linedriver)
Max. Permissible Shaft Loading	Radial 60 N Axial 40 N
Max. Speed	3500 rpm
Shaft Diameter	Ø6 - 8 - 10 mm
Shaft Material	Stainless steel
Case Diameter	Ø58 mm
Case Material	Aluminium and painted steel
IP Degree	IP 54
Operating Temperature	-20°C ... +80°C
Storage Temperature	-30°C ... +90°C

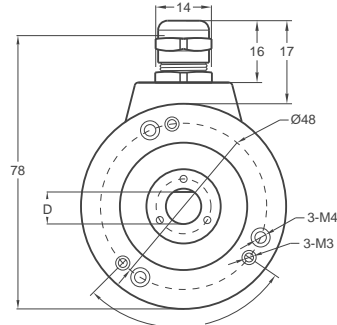
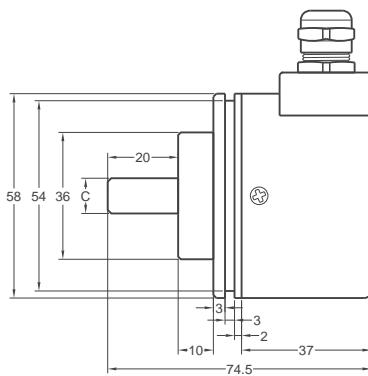

A Type (Clamping flange)

Push-Pull Cable Output

+V : Brown
 0V : White
 GND: Shield
 Ch A : Yellow
 Ch B : Green
 Ch Z : Gray

TTL - HTL Linedriver Cable Output

+V : Brown
 0V : White
 GND : Shield
 Ch A : Yellow
 Ch B : Green
 Ch Z : Gray
 Ch A inv.: Blue
 Ch B inv.: Red
 Ch Z inv.: Ping

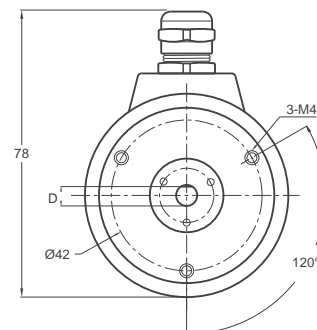
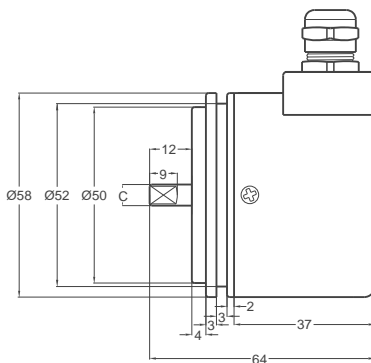

B Type (Synchro flange)

PRI 58	AR (shaft)		BR (shaft)	
	C	D	C	D
	Ø6 mm	5 mm	Ø6 mm	5 mm
	Ø8 mm	7 mm	Ø8 mm	7 mm
	Ø10 mm	9 mm	Ø10 mm	9 mm

Model	Case Diameter	Case Type	Shaft Diameter	Output Type	Resolution	Output Channels	Supply Voltage	Connector / Cable	Cable Output
(example) PRI	58	A	R8	HLD	1024	Z	V2	2M5	R
PRI	58mm	A: Clamping flange B: Synchro flange	R6 : 6mm R8 : 8mm R10: 10mm	LTP : Push-Pull LD : TTL Linedriver HLD: HTL Linedriver	100 ... 5000 ppr.	Z: A,B,Z B: A,B	V1: 5 VDC V2: 8-24 VDC V3: 5-24 VDC	2M5: 2,5 meter cable 5M : 5 meter cable 8M : 8 meter cable 10M: 10 meter cable C12: 12 pin connector	R: Radial

Optic Rotary Incremental Encoder

58 mm case diameter
 100 - 200 - 360 - 400 - 500 - 600 - 720 - 1000 - 1024
 1800 - 2000 - 2048 - 2500 ppr.
 Push-Pull, TTL Linedriver and HTL Linedriver outputs
 Shaft diameter 11 mm
 3500 rpm max.



Technical Specifications

Resolution	100 to 2500 ppr.
Output Channels	A,B,Z or $\bar{A}, \bar{A}, \bar{B}, \bar{B}, \bar{Z}, \bar{Z}$
Output Type	Push-Pull, TTL Linedriver, HTL Linedriver
Supply Voltage	5 VDC or 8 - 24 VDC or 5 - 24 VDC
Power Consumption (without load)	< 40 mA (24 VDC)
Cable	2.5m (standard) 5 wire + Shield (Push-Pull) 2.5m (standard) 8 wire + Shield (Linedriver)
Max. Permissible Shaft Loading Radial	60 N
Axial	40 N
Max. Speed	3500 rpm
Shaft Diameter	Ø11 mm
Shaft Material	Stainless steel
Case Diameter	Ø58 mm
Case Material	Aluminium and painted steel
IP Degree	IP 54
Operating Temperature	-20°C ... +80°C
Storage Temperature	-30°C ... +90°C

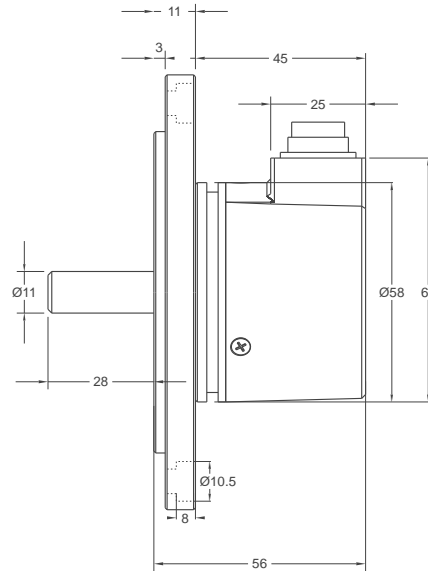
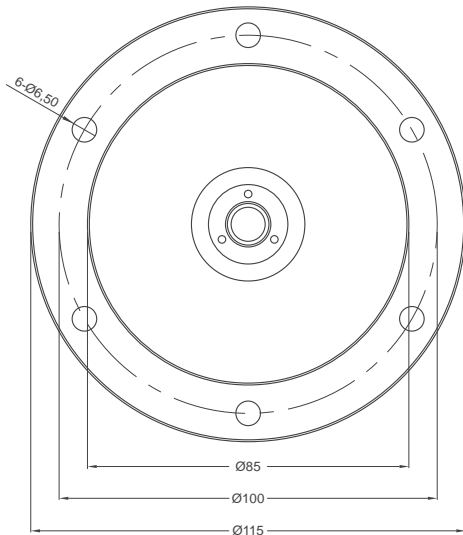

Model	Case Diameter	Case Type	Shaft Diameter	Output Type	Resolution	Output Channels	Supply Voltage	Connector / Cable	Cable Output
(example) PRI	58	RK	R11	HLD	1024	Z	V2	2M5	R
PRI	58mm	RK: Tacho flange	R11: 11mm	LTP : Push-Pull LD : TTL Linedriver HLD: HTL Linedriver	100 ... 2500 ppr.	Z: A,B,Z B: A,B	V1: 5 VDC V2: 8-24 VDC V3: 5-24 VDC	2M5: 2,5 meter cable 5M : 5 meter cable 8M : 8 meter cable 10M: 10 meter cable C12: 12 pin connector	R: Radial

Linear Potentiometers
 Linear Potentiometers Slim Body Series
 Linear Potentiometers Conditioner Circuit
 Magnetostrictive Position Sensors
 Magnetic Linear Incremental Encoders
 Draw Wire Potentiometers/Encoders
 Optic Rotary Absolute Encoders
 Magnetic Rotary Encoders
 Optic Rotary Incremental Encoders

Optic Rotary Incremental Encoder

40 mm case diameter
 100 - 200 - 250 - 300 - 360 - 400 - 500,
 512 - 600 - 1000 - 1024 - 1250 ppr.
 Push-Pull, TTL Linedriver and HTL Linedriver outputs
 Shaft diameter 6 - 8 mm
 3500 rpm max.



Technical Specifications

Resolution	100 to 1250 ppr.
Output Channels	A,B,Z or A,Ā, B,Ā, Z,Z̄
Output Type	Push-Pull, TTL Linedriver, HTL Linedriver
Supply Voltage	5 VDC, 8 - 24 VDC or 5 - 24 VDC
Power Consumption (without load)	< 40 mA (24 VDC)
Cable	1.5m (standard) 5 wire + Shield (Push-Pull) 1.5m (standard) 8 wire + Shield (Linedriver)
Max. Permissible Shaft Loading Radial	80 N
Max. Speed	3500 rpm
Shaft Diameter	Ø6 - 8 mm
Shaft Material	Stainless steel
Case Diameter	Ø40 mm
Case Material	Aluminium and painted steel
IP Degree	IP 54
Operating Temperature	-20°C ... +80°C
Storage Temperature	-30°C ... +90°C

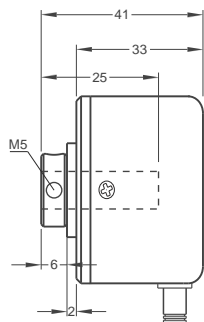

Shaft type / Radial

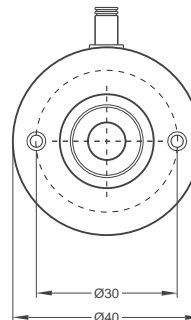

Push-Pull Cable Output

+V : Brown
 0V : White
 GND: Shield
 Ch A : Yellow
 Ch B : Green
 Ch Z : Gray

TTL - HTL Linedriver Cable Output

+V : Brown
 0V : White
 GND : Shield
 Ch A : Yellow
 Ch B : Green
 Ch Z : Gray
 Ch A inv.: Blue
 Ch B inv.: Red
 Ch Z inv.: Pink

Model	Case Diameter	Case Type	Shaft Diameter	Output Type	Resolution	Output Channels	Supply Voltage	Connector / Cable	Cable Output
(example) PRI	40	SH	R6	HLD	1250	Z	V2	2M5	R
PRI	40mm	SH: Semi hollow	R6: 6mm R8: 8mm	LTP : Push-Pull LD :TTL Linedriver HLD: HTL Linedriver	100 ... 1250 ppr.	Z :A,B,Z B :Ā,B̄ Z̄: Ā,Ā, Z̄	V1: 5 VDC V2: 8-24 VDC V3: 5-24 VDC	2M5: 2,5 meter cable 5M : 5 meter cable	R: Radial

Optic Rotary Incremental Encoder

50 mm case diameter
 Hollow and semi-hollow shaft
 100 - 200 - 360 - 400 - 500 - 600 - 720 - 1000 - 1024
 1800 - 2000 - 2048 - 2500 - 3600 - 4000 - 4096 ppr.
 Push-Pull, TTL Linedriver and HTL Linedriver outputs
 Shaft diameter 6 - 8 - 10 - 12 - 14 - 15 mm
 3500 rpm max.

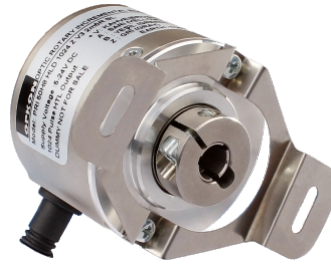

Technical Specifications

Resolution	100 to 5000 ppr.
Output Channels	A,B,Z or A,A _̄ , B,B _̄ , Z,Z _̄
Output Type	Push-Pull, TTL Linedriver, HTL Linedriver
Supply Voltage	5 VDC, 8 - 24 VDC or 5 - 24 VDC
Power Consumption (without load)	< 40 mA (24 VDC)
Cable	2.5m (standard) 5 wire + Shield (Push-Pull) 2.5m (standard) 8 wire + Shield (Linedriver)
Max. Permissible Shaft Loading Radial	100 N
Axial	60 N
Max. Speed	3500 rpm
Shaft Diameter	Ø6 - 8 - 10 - 12 - 14 - 15 mm
Shaft Material	Stainless steel
Case Diameter	Ø50 mm
Case Material	Aluminium and painted steel
IP Degree	IP 54
Operating Temperature	-20°C ... +80°C
Storage Temperature	-30°C ... +90°C

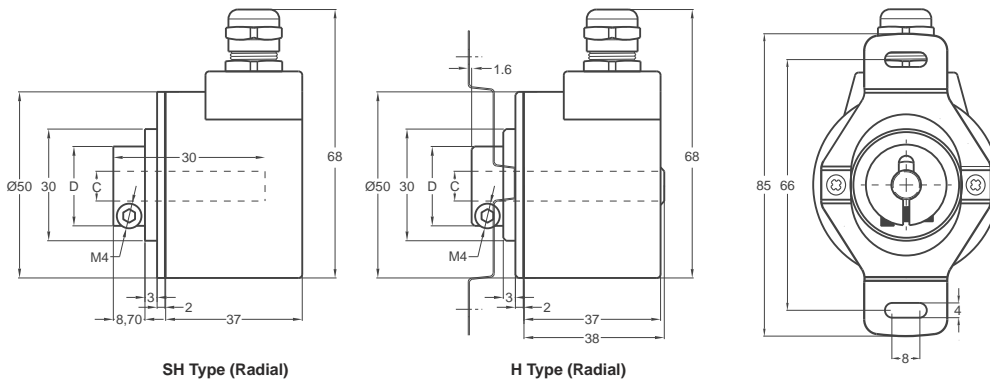

PRI 50SH / H	SH (semi hollow) / H (hollow)	
	C	D
	Ø6 mm	20 mm
	Ø8 mm	22 mm
	Ø10 mm	23,5 mm
	Ø12 mm	23,5 mm
	Ø14 mm	29,5 mm
	Ø15 mm	29,5 mm

Push-Pull Cable Output

+V : Brown
 0V : White
 GND : Shield
 Ch A : Yellow
 Ch B : Green
 Ch Z : Gray

TTL - HTL Linedriver Cable Output

+V : Brown
 0V : White
 GND : Shield
 Ch A : Yellow
 Ch B : Green
 Ch Z : Gray
 Ch A inv.: Blue
 Ch B inv.: Red
 Ch Z inv.: Pink

Model	Case Diameter	Case Type	Shaft Diameter	Output Type	Resolution	Output Channels	Supply Voltage	Connector / Cable	Cable Output
(example) PRI	50	SH	8	HLD	1024	Z	V2	2M5	R
PRI	50mm	SH: Semi hollow H : Hollow	6 : 6 mm 8 : 8 mm 10: 10 mm 12: 12 mm 14: 14 mm 15: 15 mm	LTP : Push-Pull LD : TTL Linedriver HLD: HTL Linedriver	100 ... 5000 ppr.	Z: A,B,Z B: A,B	V1: 5 VDC V2: 8-24 VDC V3: 5-24 VDC	2M5: 2,5 meter cable 5M : 5 meter cable 8M : 8 meter cable 10M: 10 meter cable C12: 12 pin connector	R: Radial

Linear Potentiometers
 Linear Potentiometers Slim Body Series
 Linear Potentiometers Conditioner Circuit
 Magnetostrictive Position Sensors
 Magnetic Linear Incremental Encoders
 Draw Wire Potentiometers/Encoders
 Optic Rotary Absolute Encoders
 Magnetic Rotary Encoders
 Optic Rotary Incremental Encoders

PRI 58SH PRI 58H

Optic Rotary Incremental Encoder



58 mm case diameter
 Hollow and semi-hollow shaft
 100 - 200 - 360 - 400 - 500 - 600 - 720 - 1000 - 1024
 1800 - 2000 - 2048 - 2500 - 3600 - 4000 - 4096 - 5000 ppr.
 Push-Pull, TTL Linedriver and HTL Linedriver outputs
 Shaft diameter 6 - 8 - 10 - 12 - 14 - 15 mm
 3500 rpm max.

Technical Specifications

Resolution	100 to 5000 ppr.
Output Channels	A,B,Z or A,Ā, B,Ā, Z, Z̄
Output Type	Push-Pull, TTL Linedriver, HTL Linedriver
Supply Voltage	5 VDC, 8 - 24 VDC or 5 - 24 VDC
Power Consumption (without load)	< 40 mA (24 VDC)
Cable	2.5m (standard) 5 wire + Shield (Push-Pull) 2.5m (standard) 8 wire + Shield (Linedriver)
Max. Permissible Shaft Loading	Radial 60 N Axial 40 N
Max. Speed	3500 rpm
Shaft Diameter	Ø6 - 8 - 10 - 12 - 14 - 15 mm
Shaft Material	Stainless steel
Case Diameter	Ø58 mm
Case Material	Aluminium and painted steel
IP Degree	IP 54
Operating Temperature	-20°C ... +80°C
Storage Temperature	-30°C ... +90°C

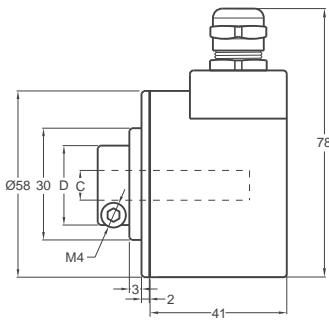

SH Type (Radial)

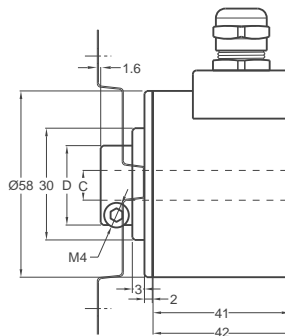

H Type (Radial)

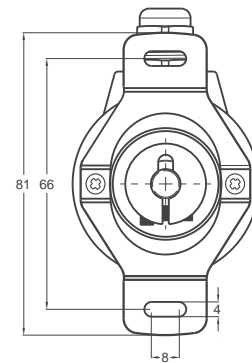

PRI 58SH / H	SH (semi hollow) / H (hollow)	
	C	D
	Ø6 mm	20 mm
	Ø8 mm	22 mm
	Ø10 mm	23,5 mm
	Ø12 mm	23,5 mm
	Ø14 mm	29,5 mm
	Ø15 mm	29,5 mm

Push-Pull Cable Output

+V : Brown
 0V : White
 GND : Shield
 Ch A : Yellow
 Ch B : Green
 Ch Z : Gray

TTL - HTL Linedriver Cable Output

+V : Brown
 0V : White
 GND : Shield
 Ch A : Yellow
 Ch B : Green
 Ch Z : Gray
 Ch A inv.: Blue
 Ch B inv.: Red
 Ch Z inv.: Pink

Model	Case Diameter	Case Type	Shaft Diameter	Output Type	Resolution	Output Channels	Supply Voltage	Connector / Cable	Cable Output
(example) PRI	58	SH	8	HLD	1024	Z	V2	2M5	R
PRI	58mm	SH: Semi hollow H : Hollow	6 : 6 mm 8 : 8 mm 10: 10 mm 12: 12 mm 14: 14 mm 15: 15 mm	LTP : Push-Pull TTL : TTL Linedriver HLD: HTL Linedriver	100 ... 5000 ppr.	Z: A,B,Z B: A,B	V1: 5 VDC V2: 8-24 VDC V3: 5-24 VDC	2M5: 2,5 meter cable 5M : 5 meter cable 8M : 8 meter cable 10M: 10 meter cable C12: 12 pin connector	R: Radial

Optic Rotary Incremental Encoder

80 mm case diameter
 1024 ppr.
 Hollow shaft diameter 16 - 20 - 22 - 24 - 25 - 28 - 30 - 40 - 42 mm
 3500 rpm max.
 Lift and elevator applications



Technical Specifications

Resolution	1024 ppr.
Output Channels	A,B,Z or A _A , B _B , Z _Z
Output Type	Push-Pull, TTL Linedriver, HTL Linedriver
Supply Voltage	5 VDC, 8 - 24 VDC or 5 - 24 VDC
Power Consumption (without load)	< 40 mA (24 VDC)
Cable	2.5m (standard) 5 wire + Shield (Push-Pull) 2.5m (standard) 8 wire + Shield (Linedriver)
Max. Permissible Shaft Loading Radial	180 N
Axial	80 N
Max. Speed	3500 rpm
Shaft Diameter	Ø16 - 20 - 22 - 24 - 25 - 28 - 30 - 40 - 42mm
Shaft Material	Aluminium
Case Diameter	Ø80 mm
Case Material	Aluminium and painted steel
IP Degree	IP 50
Operating Temperature	-20°C ... +80°C
Storage Temperature	-30°C ... +90°C

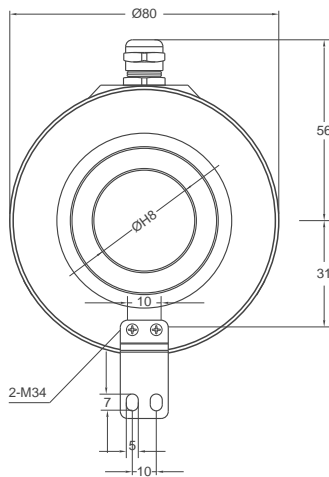

H Type (Radial)

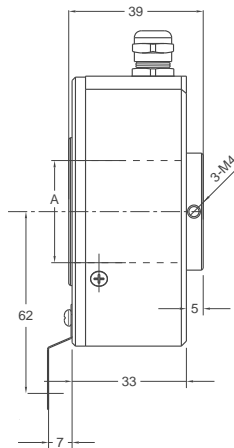

Shaft Diameter (A)
16
20
22
24
25
28
30
40
42

Linedriver Cable Output

- Ch A : Yellow
- Ch A inv.: Blue
- Ch B : Green
- Ch B inv.: Red
- Ch Z : Gray
- Ch Z inv.: Pink
- +V : Brown
- 0V : White
- GND : Shield

Push-Pull Cable Output

- Ch A : Yellow
- Ch B : Green
- +V : Brown
- 0V : White
- GND : Shield

Model	Case Diameter	Case Type	Shaft Diameter	Output Type	Resolution	Output Channels	Supply Voltage	Connector / Cable	Cable Output
(example) PRI	80	H	25	LTP	1024	Z	V2	2M5	R
PRI	80	H: Hollow	16: 16mm 30: 30mm 20: 20mm 40: 40mm 22: 22mm 42: 42mm 24: 24mm 25: 25mm 28: 28mm	LTP : Push-Pull LD : TTL Linedriver HLD: HTL Linedriver	1024 ppr.	Z: A,B,Z B: A,B	V1: 5 VDC V2: 8-24 VDC V3: 5-24 VDC	2M5: 2,5 meter cable 5M : 5 meter cable 8M : 8 meter cable 10M: 10 meter cable C12: 12 pin connector	R: Radial

Linear Potentiometers
 Linear Potentiometers Slim Body Series
 Linear Potentiometers Conditioner Circuit
 Magnetostrictive Position Sensors
 Magnetic Linear Incremental Encoders
 Draw Wire Potentiometers/Encoders
 Optic Rotary Absolute Encoders
 Magnetic Rotary Encoders
 Optic Rotary Incremental Encoders

PRI 100H

Optic Rotary Incremental Encoder

100 mm case diameter
1024 ppr.
Hollow shaft diameter 25 - 28 - 30 - 35 - 38 - 40 - 42 mm
3500 rpm max.
Lift and elevator applications



Technical Specifications

Resolution	1024 ppr.
Output Channels	A,B,Z or A ₊ A ₋ , B ₊ B ₋ , Z ₊ Z ₋
Output Type	Push-Pull, TTL Linedriver, HTL Linedriver
Supply Voltage	5 VDC, 8 - 24 VDC or 5 - 24 VDC
Power Consumption (without load)	< 40 mA (24 VDC)
Cable	2.5m (standard) 5 wire + Shield (Push-Pull) 2.5m (standard) 8 wire + Shield (Linedriver)
Max. Permissible Shaft Loading	Radial 180 N Axial 80 N
Max. Speed	3500 rpm
Shaft Diameter	Ø25 - 28 - 30 - 35 - 38 - 40 - 42 mm
Shaft Material	Aluminium
Case Diameter	Ø100 mm
Case Material	Aluminium and painted steel
IP Degree	IP 50
Operating Temperature	-20°C ... +80°C
Storage Temperature	-30°C ... +90°C

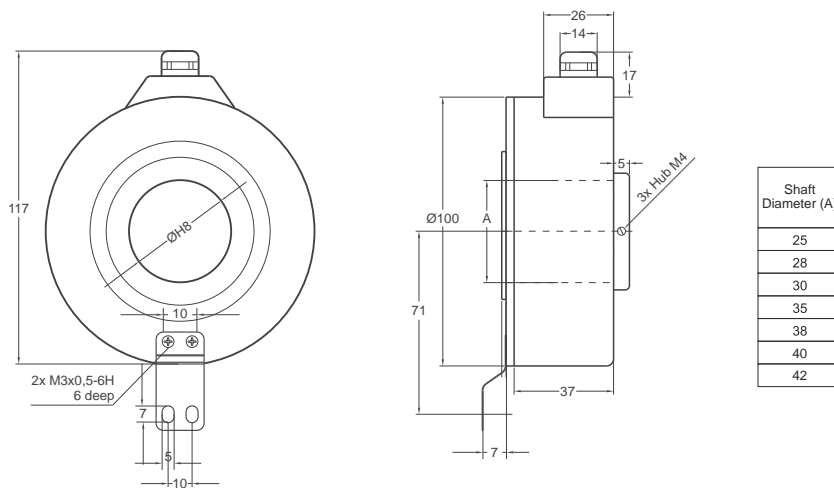

H Type (Radial)

Linedriver Cable Output

Ch A : Yellow
Ch A inv.: Blue
Ch B : Green
Ch B inv.: Red
Ch Z : Gray
Ch Z inv.: Pink
+V : Brown
0V : White
GND : Shield

Push-Pull Cable Output

Ch A : Yellow
Ch B : Green
+V : Brown
0V : White
GND : Shield

Model	Case Diameter	Case Type	Shaft Diameter	Output Type	Resolution	Output Channels	Supply Voltage	Connector / Cable	Cable Output
(example) PRI	100	H	25	LTP	1024	Z	V2	2M5	R
PRI	100	H: Hollow	25: 25mm 28: 28mm 30: 30mm 35: 35mm 38: 38mm	LTP : Push-Pull LD : TTL Linedriver HLD: HTL Linedriver	1024 ppr.	Z: A,B,Z B: A,B	V1: 5 VDC V2: 8-24 VDC V3: 5-24 VDC	2M5: 2,5 meter cable 5M : 5 meter cable 8M : 8 meter cable 10M: 10 meter cable C12: 12 pin connector	R: Radial

NOTE

A series of horizontal dashed lines for writing notes.

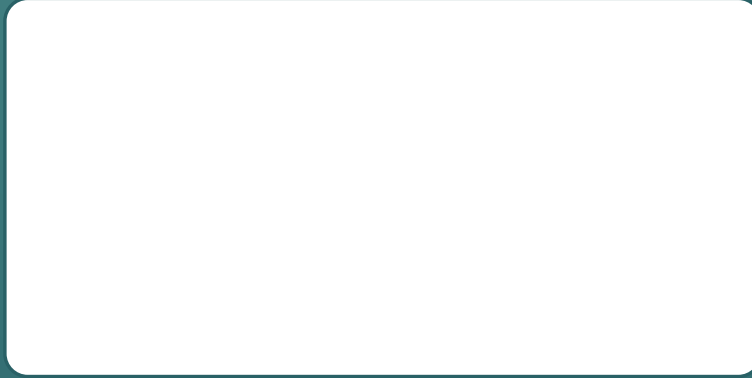

www.kosgeb.gov.tr

Basım Yeri : HAT BASKI SANATLARI
SAN. VE T.C. LTD. T.
Basım tarihi :
Basım adeti : 1000 adet



OPKON OPTİK ELEKTRONİK KONTROL SAN. T.C. LTD. T.
Terazidere Mah. 60. Yıl Cad. No: 46
Bayrampaşa / STANBUL / TÜRKİYE
Tel : +90 (212) 501 48 63 Pbx. Fax : +90 (212) 501 48 83
info@opkon.com.tr